

M-16-34
REV. C
APRIL 2021

MAXON®

TE-20 TE-25 TE-30

OPERATION MANUAL

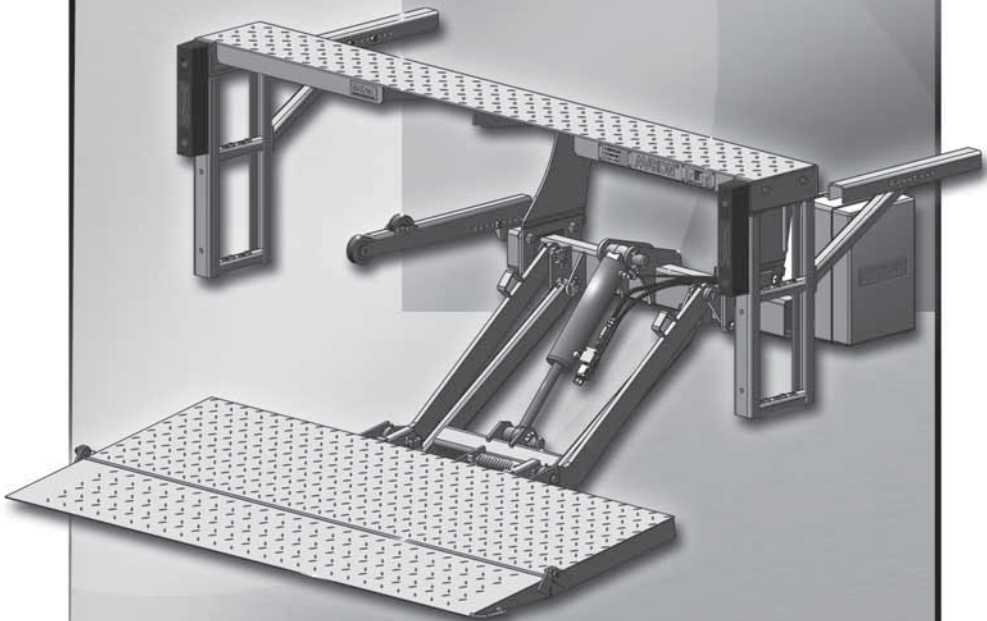

To find **maintenance & parts** information for your **TE-20, TE-25 or TE-30 Liftgate**, go to www.maxonlift.com. Click the **PRODUCTS, TUK-A-WAY & TE-20 or TE-25/TE-30** buttons. Open the **Maintenance Manual** in the **PRODUCT DOCUMENTATION** window. For parts, click on the **PARTS PORTAL, TUK-A-WAY & TE-20 or TE-25/TE-30** buttons.

KEEP THIS MANUAL IN CAB OF VEHICLE

Register your liftgate on line at www.maxonlift.com/htm/services/reg.htm.

For a free copy of other manuals that pertain to this model liftgate, please visit our website at www.maxonlift.com or call Customer Service at (800) 227-4116.

© 2021 MAXON LIFT CORP.

TABLE OF CONTENTS

| | |
|---|-----------|
| SUMMARY OF CHANGES: M-16-34 REV C | 4 |
| WARNINGS | 5 |
| RECOMMENDED DAILY OPERATION CHECKS | 7 |
| DECALS | 10 |
| FORKLIFT ADVISORY | 13 |
| ROADSIDE OPERATION ADVISORY..... | 14 |
| OPERATION | 15 |
| USING CART STOPS (IF EQUIPPED) | 21 |

SUMMARY OF CHANGES: M-16-34 REV C

| PAGE | DESCRIPTION OF CHANGE |
|--------------|--|
| Cover | Updated revision, date & copyright statement. |
| | Deleted references to TE-15 throughout manual. |

WARNING

1. Incorrect operation of this Liftgate can result in serious personal injury. Comply with **WARNINGS** and Liftgate operating instructions in this manual. Do not allow untrained persons or children to operate the Liftgate. If you need to replace an **Operation Manual**, additional copies are available from:

MAXON Lift Corp.
11921 Slauson Ave
Santa Fe Springs, CA 90670
(800) 227-4116

NOTE: For latest version manuals (and replacements), download manuals from Maxon's website at **www.maxonlift.com**.

2. Do not exceed rated load capacity of the Liftgate which is **2000 LB for model TE-20, 2500 LB for model TE-25 and 3000 LB for model TE-30**.
3. Do not allow any part of your body to be placed under, within, or around any portion of the moving Liftgate or its mechanisms, or in a position that would trap them between the platform and the floor of truck body (or between platform and the ground) when Liftgate is operated.
4. Consider the safety and location of bystanders and location of nearby objects when operating the Liftgate. Stand to one side of platform while operating the Liftgate. Be certain that the area the Liftgate will move through during operation is clear of all obstacles.
5. Comply with all attached instruction decals and warning decals.
6. Keep decals clean and legible. If decals are illegible or missing, have them replaced. **Get free replacement decals from Maxon.**
7. **Never drive a forklift on the Liftgate platform.**
8. Do not move vehicle unless Liftgate is correctly stowed.
9. **Correctly stow platform when not in use. Extended platforms could create a hazard for people and vehicles passing by.**
10. A correctly installed Liftgate will operate smoothly and reasonably quiet. The only noticeable noise, during Liftgate operation, is from the power unit while the platform is raised. Listen for scraping, grating and binding noises and have the problem corrected before continuing to operate the Liftgate.
11. Above all, **USE GOOD COMMON SENSE** when operating this Liftgate.
12. Never use a cell phone while operating the Liftgate.

LIFTGATE TERMINOLOGY

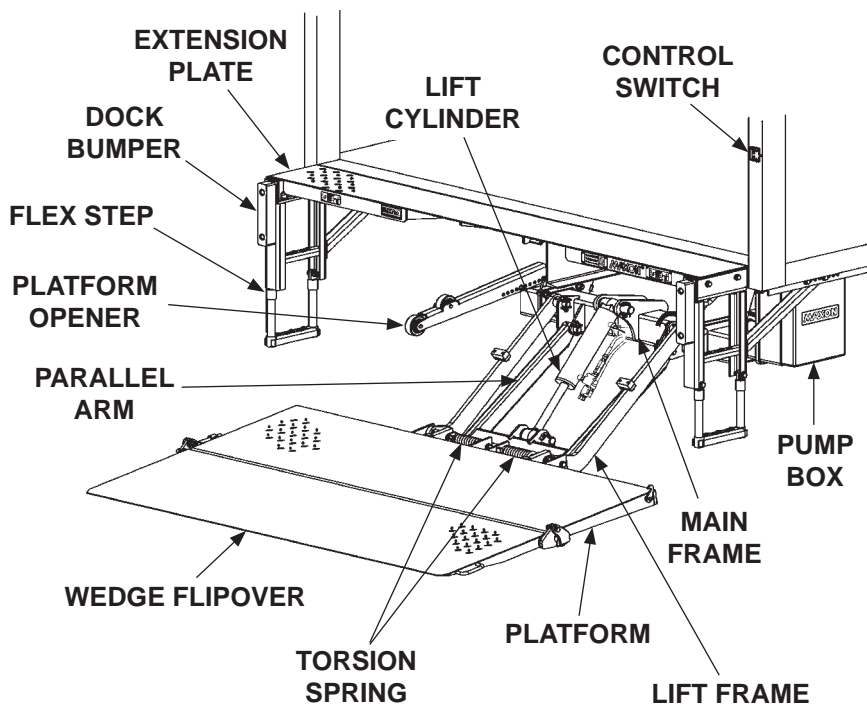

TE-25 OR TE-30 SHOWN
FIG. 6-1

RECOMMENDED DAILY OPERATION CHECKS

NOTE: Before you check the Liftgate, park vehicle on flat ground and set the parking brake.

NOTE: If any of the following operation checks reveal a need to service or repair Liftgate, do not operate the Liftgate until a qualified mechanic services or repairs the Liftgate.

Before operating the Liftgate, the operator should do the following:

- Make sure vehicle battery is fully charged and battery terminal connections are clean and tight.
- Visually check that pump cover is bolted on securely and undamaged. Look for hydraulic fluid leaking from the pump box.
- Visually check that control switch is in place and undamaged.
- Visually check for cracks and bends on the extension plate. Also, make sure fasteners are in place and undamaged and extension plate is clean (no oil, debris, or corrosion).
- Visually check that all decals are in place (see **DECALS** page). Also, make sure decals are legible, clean, and undamaged.

Use the operation instructions in this manual to lower the Liftgate to the ground and open the platform and flipover.

- Check main frame, lift arms, parallel arms and platform openers for cracks and bends. Make sure rollers, on the platform openers, roll freely. Also, make sure all bolts and pins are in place and undamaged.
- Make sure main frame, lift arms, parallel arms and platform openers are clean (no oil, debris, or corrosion).
- Check the hydraulic cylinders for leaking seals and hose connections. Follow the hydraulic hoses (or return lines for gravity down Liftgates) from the cylinders to pump box. Make sure all hoses are connected at both ends and there are no cracks, chafing, and fluid leaks.

RECOMMENDED DAILY OPERATION CHECKS - Continued

- With the platform at vehicle bed height and no load on platform, outboard edge of platform must be higher than extension plate as shown in the **YES illustration (FIG. 8-1)**. If the platform is tilted up like the **YES illustration**, you can operate Liftgate. If platform is level at bed height like the **NO illustration (FIG. 8-2)**, do not operate the Liftgate. (See **NOTE** at beginning of the **DAILY OPERATION CHECKS**.)

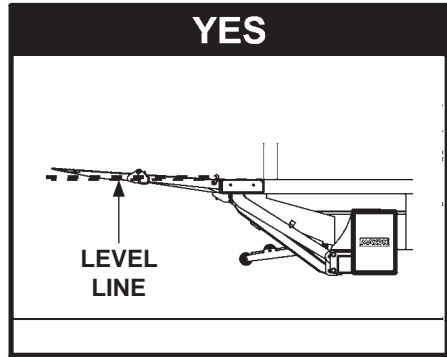

**PLATFORM AT BED HEIGHT
FIG. 8-1**

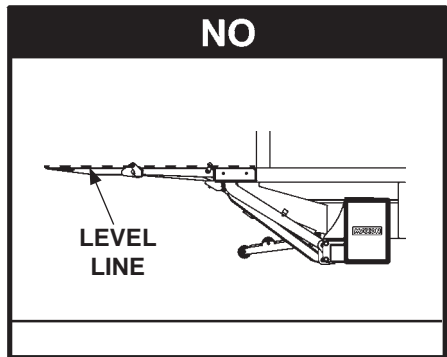

**PLATFORM AT BED HEIGHT
FIG. 8-2**

- With the platform unfolded and on the ground, check if the shackles and the tip of platform touch the ground at the same time as shown in the **YES illustration (FIG. 9-1)**. If the platform looks like the **YES illustration**, you can operate Liftgate. If the tip of the platform is off the ground and platform looks like the **NO illustration (FIG. 9-2)**, or if the shackles are off the ground, do not operate the Liftgate. (See **NOTE** at beginning of the **DAILY OPERATION CHECKS**.)

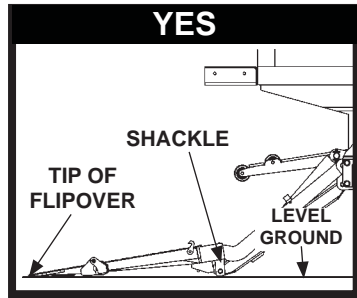

**PLATFORM UNFOLDED
ON THE GROUND
FIG. 9-1**

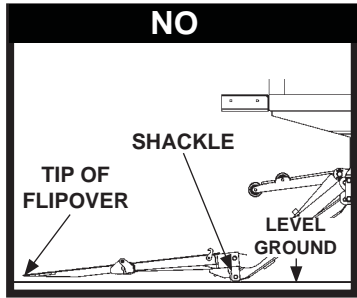

**PLATFORM TIP OFF
THE GROUND
FIG. 9-2**

- Check the platform and flipover for cracks, holes, and bends on the load-carrying surface and side plates. Also, make sure torsion bars, coil springs, and fasteners are in place and undamaged.
- Make sure platform and flipover load-carrying surfaces are clean (no oil, debris, or corrosion).

Use the operation instructions in this manual to operate the Liftgate through one cycle without a load on the platform. RAISE the platform to vehicle bed height. Next, lower the platform to ground level.

- When the Liftgate is moving, listen for unusual noises and look for jerking motion or uneven movement on either side of the platform.

If service or repairs are not required (or if completed), stow the Liftgate.

DECALS

NOTE: Ensure there is no residue, dirt or corrosion where decals are attached. If necessary, clean surface before attaching decals.

NOTE: Preferred decal layout is shown, Decals on the Liftgate are attached at the factory. If vehicle does not permit this layout, decals in the manual and decal kit must be applied so that they are easily visible when approaching vehicle to operate Liftgate. Use good common sense when locating these decals on vehicle.

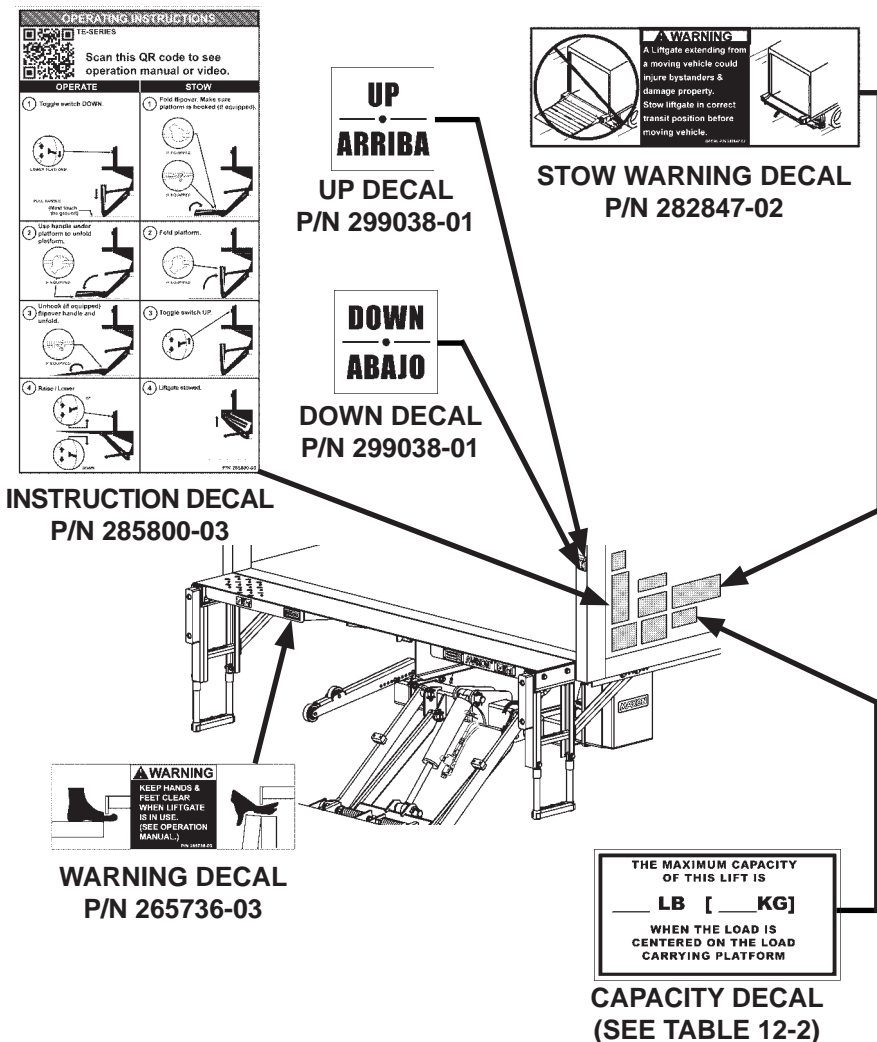
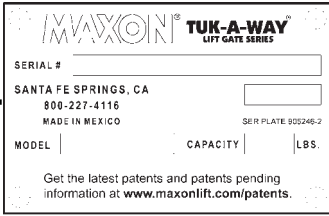

FIG. 10-1



SERIAL PLATE (REF)



PARTS QR CODE DECAL
P/N 299348-01 (TE-20)
P/N 299348-02 (TE-25,TE-30)

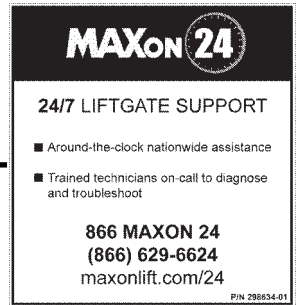
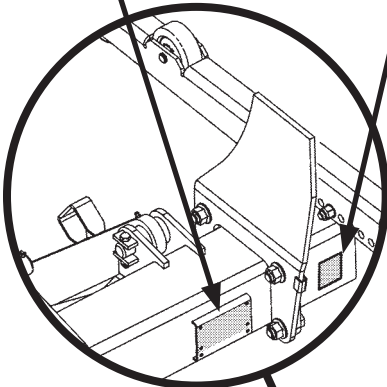

MAXON 24/7 SUPPORT DECAL
P/N 298634-01

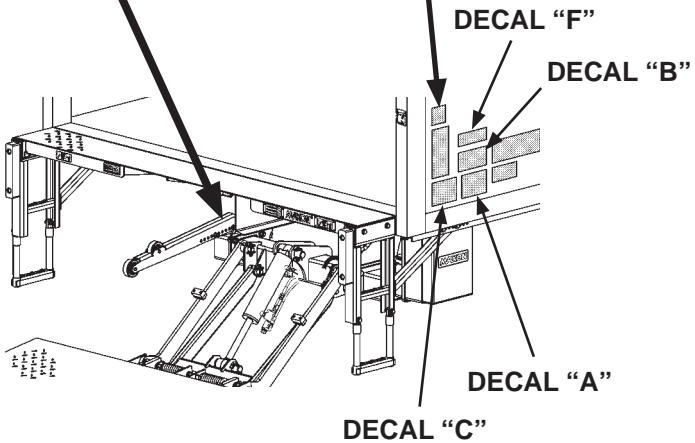

FIG. 11-1

DECALS - Continued

SAFETY INSTRUCTIONS

Read all decals and operation manual before operating liftgate.

1. Do not use liftgate unless you have been properly instructed and have read, and are familiar with, the operating instructions.
2. Be certain vehicle is properly and securely braked before using the liftgate.
3. Always inspect this liftgate for maintenance or damage before using it. Do not use liftgate if it shows any sign of damage or improper maintenance.
4. Do not overload.
5. Make certain the area in which the platform will open and close is clear before opening or closing the platform.
6. Make certain platform area, including the area in which loads may fall from platform, is clear before and at all times during operation of liftgate.
7. This liftgate is intended for loading and unloading of cargo only. Do not use this liftgate for anything but its intended use.

(A)

WARNING

Read this information carefully.

- Improper operation of this Liftgate can result in serious personal injury. If you do not have a copy of the operating instructions, please obtain them from your employer, distributor, or lessor before you attempt to operate Liftgate.
- If there are signs of improper maintenance, damage to vital parts, or slippery platform surface, do not use the Liftgate until these problems have been corrected.
- If you are using a pallet jack, be sure it can be maneuvered safely.
- Do not operate a forklift on the platform.
- Do not allow any part of yours or your helper's body to be placed under, within, or around any portion of the moving Liftgate, or its mechanisms, or in a position that would trap them between the platform and the ground or truck when the Liftgate is operated.
- If a helper is riding the platform with you, make sure you are both doing so safely and that you are not in danger of coming in contact with any moving or potentially moving obstacles.
- **USE GOOD COMMON SENSE.**
- If load appears to be unsafe, do not lift or lower it.

For a free copy of other manuals that pertain to this model Liftgate, please visit our website at www.maxonlift.com or call Customer Service at (800) 227-4116.

(C)



DECAL SHEET P/N 282522-01 FIG. 12-1

| MODEL | DECAL P/N | CAPACITY |
|-------|-----------|-----------------------|
| TE-20 | 220387 | 2000 POUNDS (907 KG) |
| TE-25 | 220382 | 2500 POUNDS [1134 KG] |
| TE-30 | 220388 | 3000 POUNDS [1360 KG] |

CAPACITY DECALS TABLE 12-1

FORKLIFT ADVISORY

⚠ WARNING

Keep Forklift OFF of Platform.

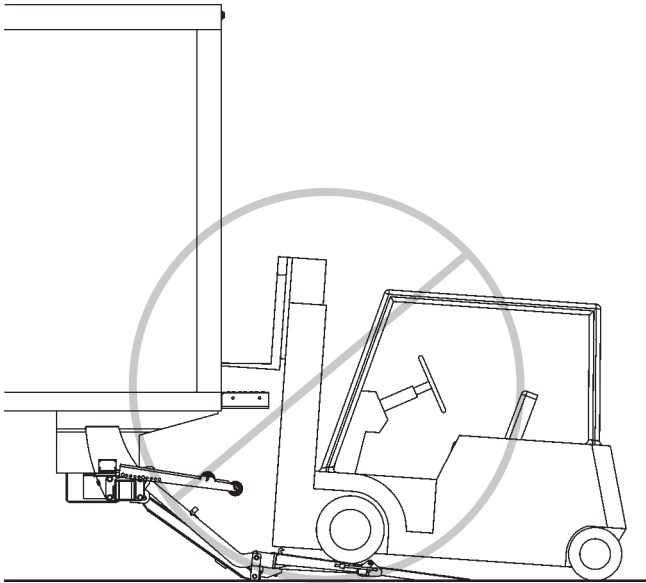
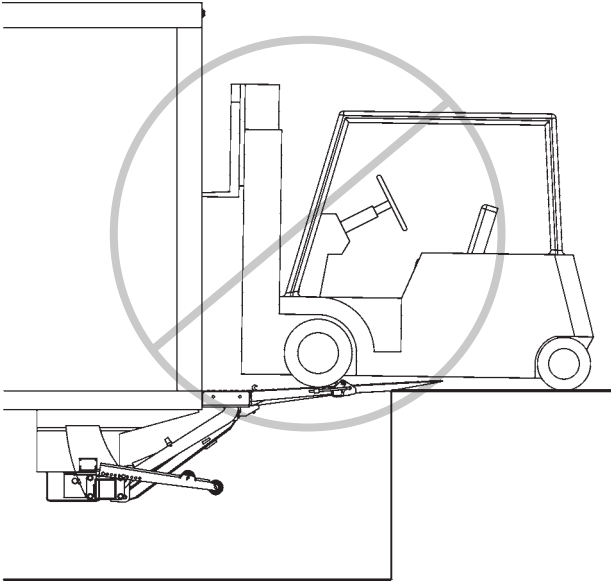

FIG. 13-1

ROADSIDE OPERATION ADVISORY

WARNING

Operating the Liftgate by the side of a busy road with vehicle traffic increases the chance of personal injury and damage to Liftgate, cargo & vehicle. Making the loading area more visible to passing traffic can help reduce the chance of injury and damage.

NOTE: MAXON recommends placing at least 2 traffic cones on the traffic side of the platform loading area as illustrated below. Remove cones after platform is stowed and before moving the vehicle.

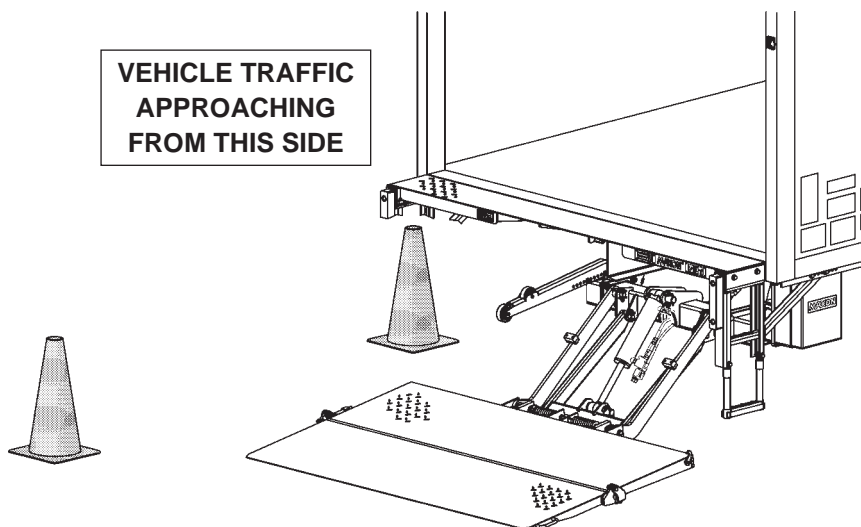

TRAFFIC CONES POSITIONED BY PLATFORM LOADING AREA
FIG. 14-1

OPERATION

WARNING

Never operate control switch while unfolding (and folding) platform and flipover. Always use handle on side of flipover to unfold (and fold) flipover. Holding the flipover any other way can create a hazard and injure operator.

1. Push the toggle switch to **DOWN** position (**FIG. 15-1A**) until shackles touch the ground.

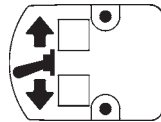
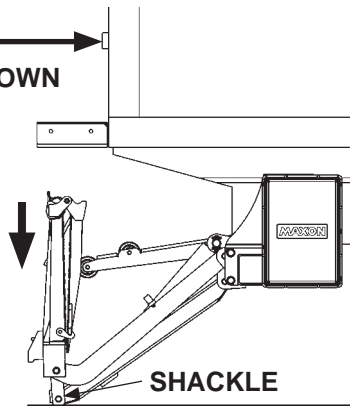

FIG. 15-1A



LOWERING PLATFORM
FIG. 15-1

2. Use handle on bottom of platform (**FIG. 15-2A**) to unfold the platform and flipover (**FIG. 15-2**).

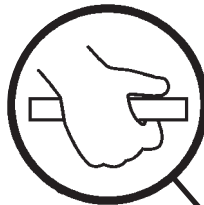
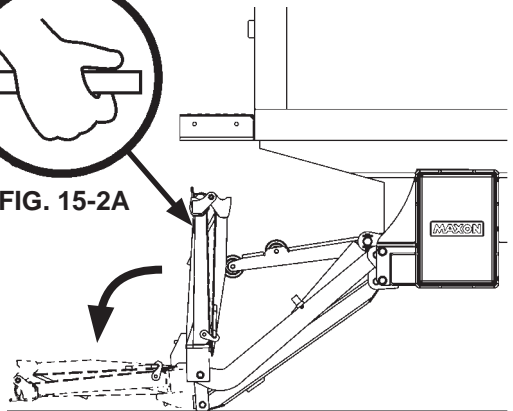

FIG. 15-2A



UNFOLDING PLATFORM & FLIPOVER
FIG. 15-2

OPERATION - Continued

3. Unhook (if equipped) and unfold the flipover as follows. If equipped with hook, press down on the flipover and rotate hook away from the handle (**FIGS. 16-1 and 16-1A**). Then, use handle (**FIG. 16-1B**) to unfold the flipover.

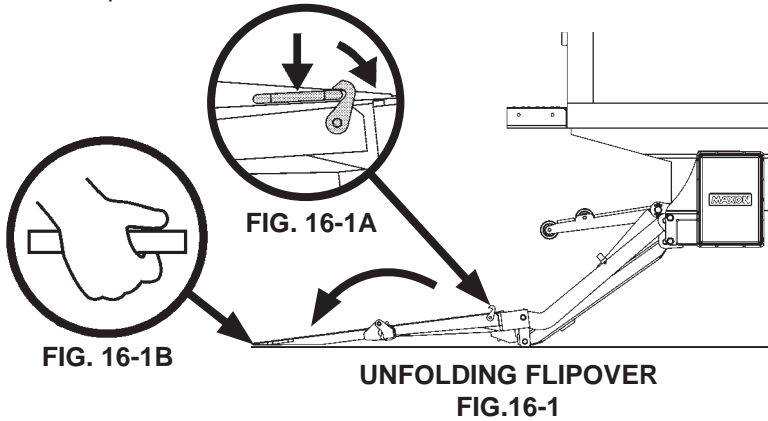

NOTE: While operating the Liftgate, release toggle switch to stop the platform.

4. Raise the platform (**FIG. 16-2**) by pushing the toggle switch to the **UP** position (**FIG. 16-2A**). If loading (or unloading) the platform, wait a second before releasing the toggle switch, after platform reaches bed height. To lower the platform, push the toggle switch to the **DOWN** position (**FIG. 16-2B**).

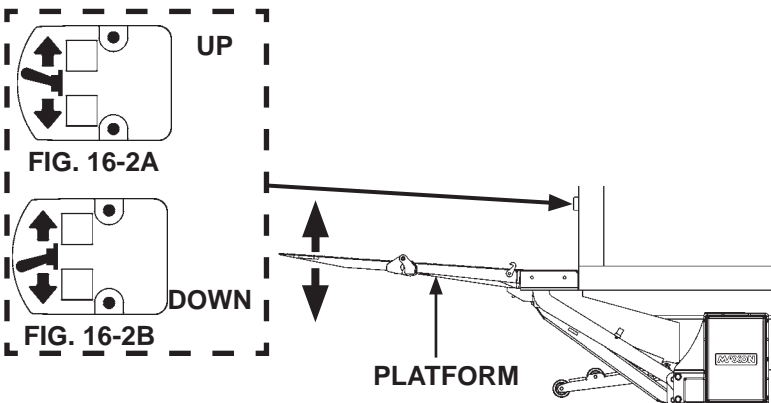

**RAISING & LOWERING PLATFORM
FIG. 16-2**

⚠ WARNING

A load should never extend past the edges of the platform. Do not place unstable loads on platform and do not allow load to exceed the lifting capacity of the Liftgate. If standing on platform, do not allow your feet to extend beyond the inboard edge of the platform.

5. Load the platform at ground level as shown in FIG. 17-1.

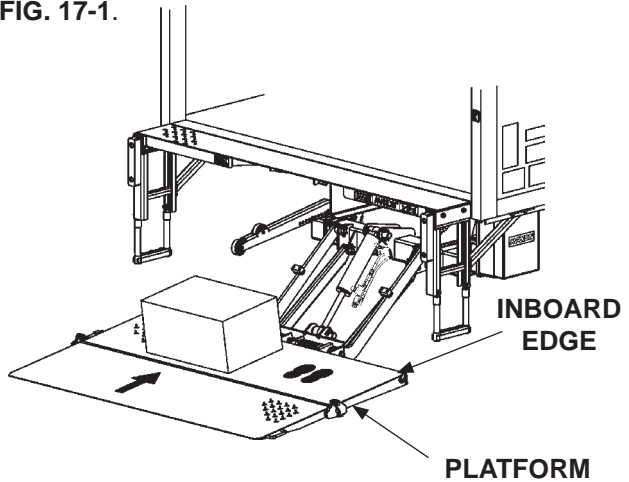

**LOADING PLATFORM AT GROUND LEVEL
FIG. 17-1**

6. Raise the platform to bed height (FIG. 17-2). Move the load off platform into vehicle (FIG. 17-2).

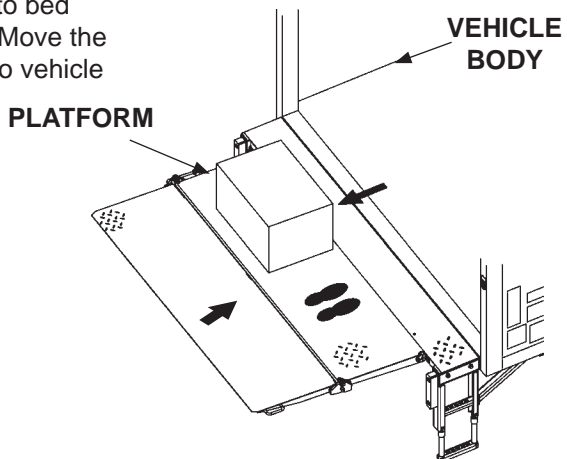

**UNLOADING PLATFORM AT BED HEIGHT
FIG. 17-2**

OPERATION - Continued

WARNING

Pulling the load from vehicle to platform can result in a fall from platform and serious injury. When unloading vehicle, always push the load out on the platform.

7. Load the platform at bed height (**FIG. 18-1**) as follows. Push load out of the vehicle to correct position on the platform. Place all loads as close as possible to the inboard edge of the platform with heaviest part toward the truck body as shown in **FIG. 18-1**. If standing on platform with the load, stand in the footprint area shown and comply with the **WARNING** on previous page.

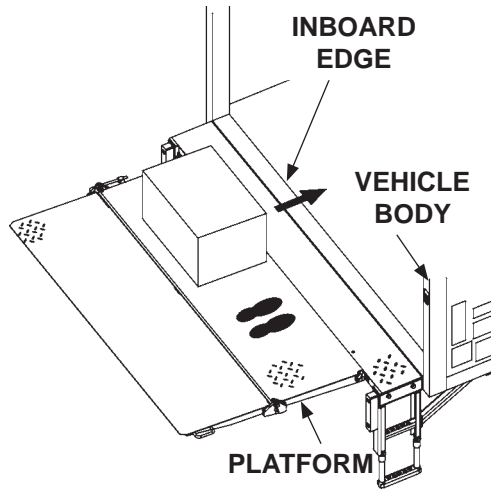

LOADING PLATFORM AT BED HEIGHT
FIG. 18-1

8. Lower the platform to ground level (**FIG. 18-2**). Move load off the platform (**FIG. 18-2**).

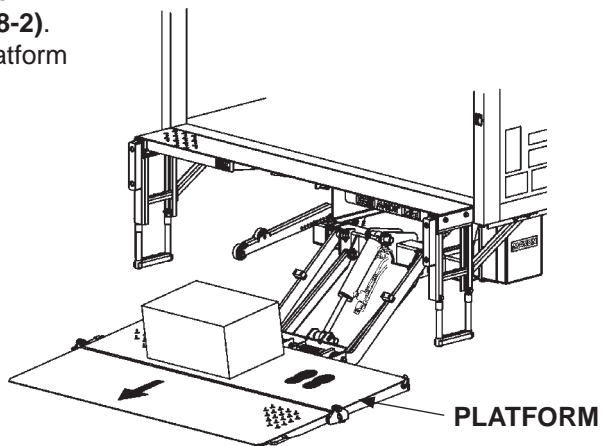

UNLOADING PLATFORM AT GROUND LEVEL
FIG. 18-2

WARNING

Never move the vehicle unless the Liftgate is properly stowed.

NOTE: Platform raised off the ground makes it easier to grasp and fold the flipover.

9. Before moving the vehicle, prepare the Liftgate as follows. Make sure load is removed from platform. If the platform is at bed height, push the toggle switch to the **DOWN** position as shown in **FIG. 19-1A**. Release toggle switch when platform 2" off the ground (**FIG. 19-1**).

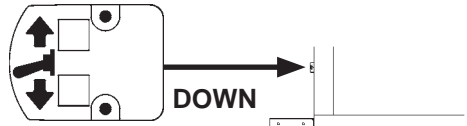
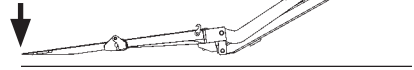

FIG. 19-1A



PLATFORM 2" OFF THE GROUND
FIG. 19-1

10. Fold flipover on the platform using handle on the flipover (**FIG. 19-2A**). If equipped, hook the platform to handle on flipover (**FIG. 19-2B**).

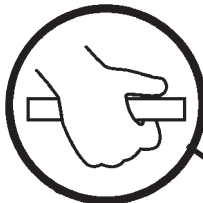

FIG. 19-2A

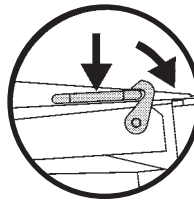
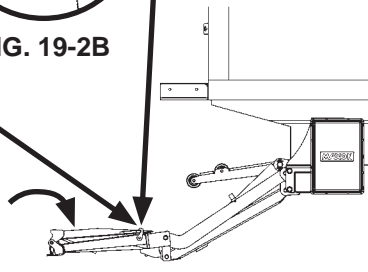

FIG. 19-2B



FOLDING FLIPOVER ON PLATFORM
FIG. 19-2

OPERATION - Continued

11. Use handle on bottom of platform (**FIG. 20-1A**) to lift and fold the platform and flipover (**FIG. 20-1**).

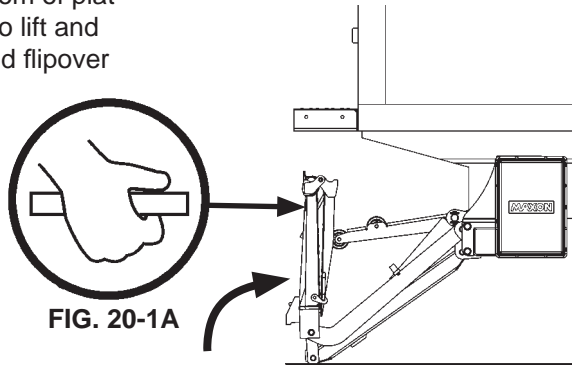

FOLDING PLATFORM & FLIPOVER
FIG. 20-1

12. Stow the platform (**FIG. 20-2**) by pushing the toggle switch to the **UP** position (**FIG. 20-2A**). Wait a second, after platform is stowed all the way, before releasing toggle switch.

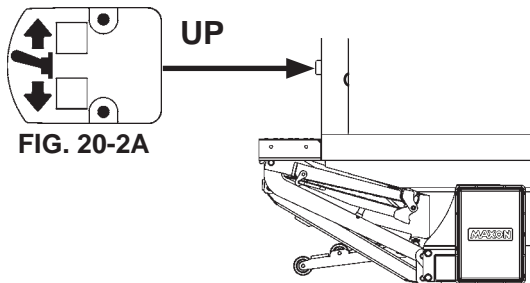

CORRECTLY STOWED PLATFORM
FIG. 20-2

13. Liftgate is ready for transport.

USING CART STOPS (IF EQUIPPED)

CAUTION

To prevent injuries caused by tripping and falling, make sure cart stops are closed before walking on and off outboard end of platform.

NOTE: Some Liftgates are equipped with single or dual cart stops. Cart stops prevent loaded carts from rolling off outboard end of platform. Single cart stops are 1 section, about the same as overall width of platform, and operate with one set of controls. Dual cart stops are 2 identical sections, with a combined width about the same as overall width of platform, and each is independently operated with separate controls (1 set of controls per cart stop). The following procedure shows dual cart stops. A single cart stop operates the same way.

NOTE: Cart stops are usually closed when not in use. If you find the carts stops are already open when rolling a load from the ground to the platform, you may roll the load over the cart stop. The cart stop will close temporarily as the load crosses and reopen when the load is off the cart stop.

1. At ground level, move load on platform with cart stops as shown in **FIG. 21-1**.

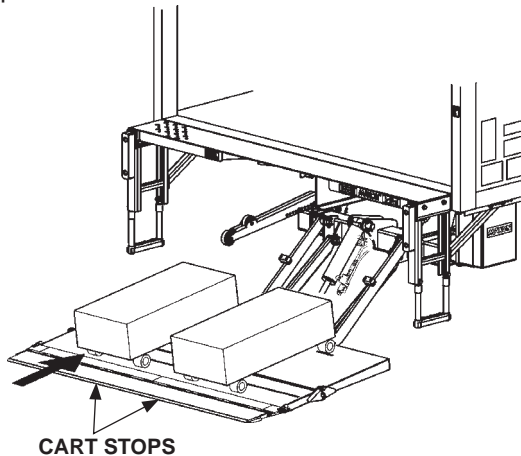

**LOADING PLATFORM AT GROUND LEVEL
(CART STOPS CLOSED)**

FIG. 21-1

USING CART STOPS (IF EQUIPPED) - Continued

NOTE: Cart stops are opened by rotating the hook (FIG. 22-1B).

2. Open cart stops (FIGS. 22-1 and 22-1A). Next, position cart and stand in the footprint area as shown in FIG. 22-1.

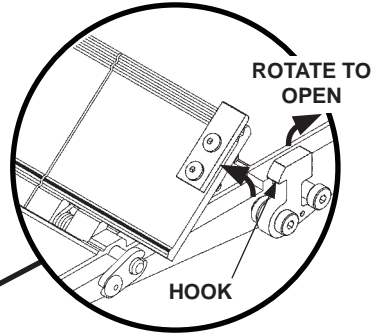

**OPENING CART STOPS
(RH SIDE OF FLIP OVER)
FIG. 22-1A**

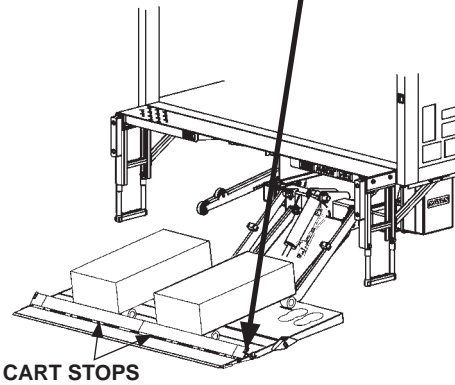

**CART STOPS OPEN
FIG. 22-1**

3. Raise the platform to bed level (FIG. 22-2). Move the load off the platform into the vehicle body (FIG. 22-2).

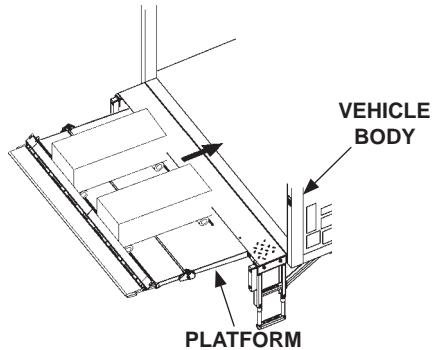

**UNLOADING PLATFORM AT BED LEVEL
(DUAL CART STOPS OPEN)
FIG. 22-2**

WARNING

Pulling the load from vehicle to platform can result in a fall from platform and serious injury. When unloading vehicle, always push the load out on the platform.

- When loading the platform at bed level, make sure cart stops are open (**FIG. 23-1**). Push load out of the vehicle to correct position on the platform. Place all loads as close as possible to the inboard edge of the platform with heaviest part toward the vehicle body as shown in **FIG. 23-1**. If standing on platform with the load, stand in the footprint area shown and comply with the **WARNING** on page 18.

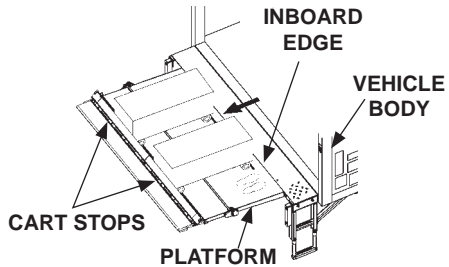

**LOADING PLATFORM AT BED LEVEL
(DUAL CART STOPS OPEN)
FIG. 23-1**

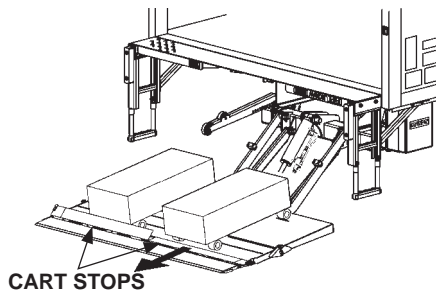

**CART STOPS CLOSED
FIG. 23-2**

NOTE: Cart stops are kept closed with a hook (**FIG. 23-3**). Make sure latch is locked.

- Unload platform with cart stop at ground level as shown in **FIG. 23-2**. Make sure cart stop is closed before moving load off the platform. To close, push the cart stop and hook in place (**FIG. 23-3**).
- Move load off the platform as shown in **FIG. 23-2**.

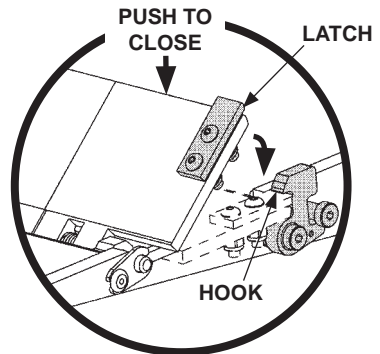

**CLOSING CART STOPS
(RH SIDE OF FLIPOVER)
FIG. 23-3**

