

INSTRUCTIONS, RAM DUAL REAR WHEEL TRUCKS INSTALLATION KIT (C2 LIFTGATES)

RAM 3500 DUAL REAR WHEEL PICKUP TRUCKS, 2013 TO 2015

KIT P/N 296427-01



LH MOUNTING BRACKET
P/N 289460-01
QTY. 1

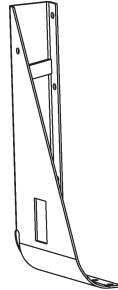

RH MOUNTING BRACKET
P/N 289460-02
QTY. 1

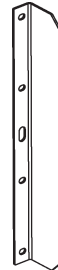

REINFORCEMENT
ANGLE
P/N 296424-01
QTY. 2



MAIN FRAME MOUNTING
BRACKET, LH
P/N 296426-01
QTY. 1

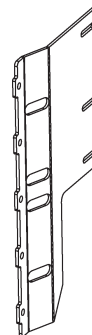

MAIN FRAME MOUNTING
BRACKET, RH
P/N 296426-02
QTY. 1

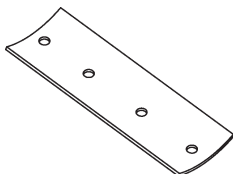

BACKPLATE
P/N 289453-01
QTY. 2

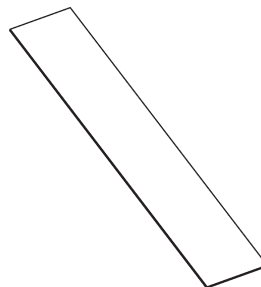

FILLER STRIP
P/N 289491-01
QTY. 3

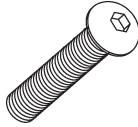
BOLT KIT, P/N 289488-01

BUTTONHEAD SCREW
3/8" - 16 X 1" LG.
P/N 900064-05
QTY. 8



PAN HEAD SCREW
#10-24 X 3/4" LG.
P/N 900753-07
QTY. 8

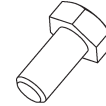

HEX CAP SCREW
3/8"-16 X 1" LG, GR5
P/N 900778-02
QTY. 12



LOCK WASHER, 3/8"
P/N 902011-4
QTY. 20



LOCK WASHER, 1/2"
P/N 902011-6
QTY. 6

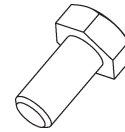

HEX CAP SCREW
1/2"- 13 X 1-1/4" LG, GR5
P/N 900781-02
QTY. 6

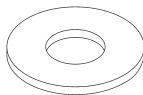

FLAT WASHER, 3/8"
P/N 902001-2
QTY. 6

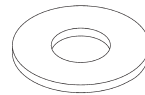

FLAT WASHER,
1-3/8" OD, 1/2"
P/N 902014
QTY. 4



HEX NUT, 3/8"-16
P/N 903161-05
QTY. 20

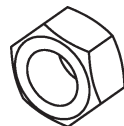

LOCK NUT, 1/2"-13
P/N 040066
QTY. 4

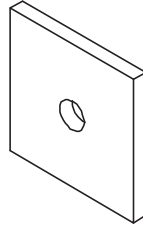
RAM DRW TRUCKS BOLT KIT, P/N 296425-01

FLAT (WASHER PLATE)
1/4" X 2-1/2" X 2-1/2"
P/N 289463-01
QTY. 4

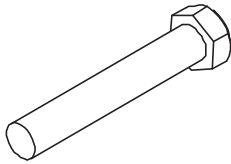

HEX CAP SCREW
1/2"-13 X 3" LG, GR5
P/N 900781-09
QTY. 1



LOCK NUT, 1/2"-13
P/N 040066
QTY. 1



LOCK WASHER, 1/2"
P/N 902011-6
QTY. 1

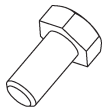

HEX CAP SCREW
3/8"-16 X 1" LG, GR5
P/N 900778-02
QTY. 2

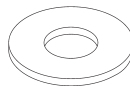

FLAT WASHER, 3/8"
P/N 902001-2
QTY. 2



LOCK WASHER, 3/8"
P/N 902011-4
QTY. 2

NOTE: C2 Liftgates are shipped with the following parts kits for installing the Liftgate.
The parts are stored in the main frame housing.

C2 LIFTGATE SMALL PARTS & MANUAL KIT P/N 289484-01

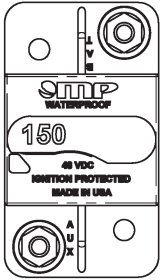

**CIRCUIT BREAKER,
150 AMP
P/N 907207-01
QTY. 1**



**LICENSE PLATE
LIGHT
P/N 907210-01
QTY. 1**

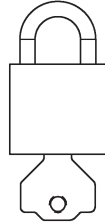

**PADLOCK (2 KEYS)
P/N 908221-01
QTY. 1**

**LICENSE
PLATE LIGHT
INSTALLATION
M-14-35**

**C2
OPERATION
MANUAL
M-14-36**



**NYLON PLUG, 1/2"
P/N 908081-01
QTY. 5**

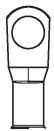

**LUG, 4GA
COPPER, 3/8"
P/N 907278-01
QTY. 4**



**BUTT CONNECTOR,
14-16 AWG
P/N 030491
QTY. 2**



**SELF-TAPPING SCREW,
1/4"-20 X 5/8" LG.
P/N 900705-02
QTY. 2**



**PAN HEAD SCREW,
#10-24 X 3/4" LG.
P/N 900007-6
QTY. 2**



**DROP-AWAY PIN
P/N 289483-01
QTY. 1**



**BREATHER PLUG, 3/8" NPT
P/N 295049
QTY. 1**



**GROMMET NUT, 1/4"
P/N 901015-03
QTY. 2**



**NUT, #10-24
P/N 903163-02
QTY. 2**



**LOCK NUT, 3/8"-16
P/N 901016-4
QTY. 1**

LOWER MOUNTING ANGLE

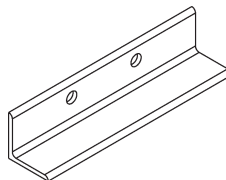

**SHIPPING LEG
P/N 289543-02
QTY. 2**

NOTE: Installer is responsible for ensuring vehicle meets Federal, State, and Local standards and regulations.

BODY STRENGTH

⚠ WARNING

Consult vehicle body manufacturer for vehicle body strength data. Make sure the forces created by the Liftgate are within the limits prescribed by the vehicle body manufacturer.

NOTE: Maximum operating bed height for C2 mounted on pickup body is 42" (Unloaded). Minimum bed height is 28" (Loaded).

The C2 is a body-mounted liftgate that puts forces on the side walls of truck bodies (FIG. 5-1). For correct installation, truck bodies must be strong enough to withstand the tension, compression and shear forces shown in FIG. 5-1.

X= Tension on each sidewall

Y= Compression on each sidewall

Z= Shear on each sidewall

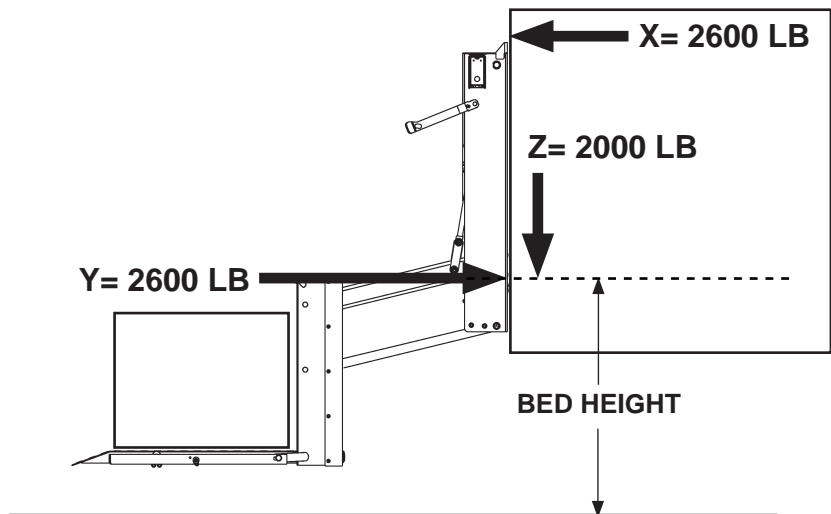

**C2 LIFTGATE SHOWN ON TRUCK BODY
FIG. 5-1**

PREPARE LIFTGATE

1. Remove mounting kits shipped with liftgate. refer to **Sheets 1 through 4**. Verify mounting brackets are the correct brackets for this installation.

⚠ CAUTION

Liftgate will not stand upright without the shipping angles. Before removing the angles, make sure Liftgate is supported with forklift or pallet jack. Injury & property damage could result if Liftgate falls over.

2. Support Liftgate on shipping pallet with forklift or pallet jack. Then, unbolt shipping angle from each column on the Liftgate (**FIG. 6-1**). Save shipping angles to use for lower mounting brackets.

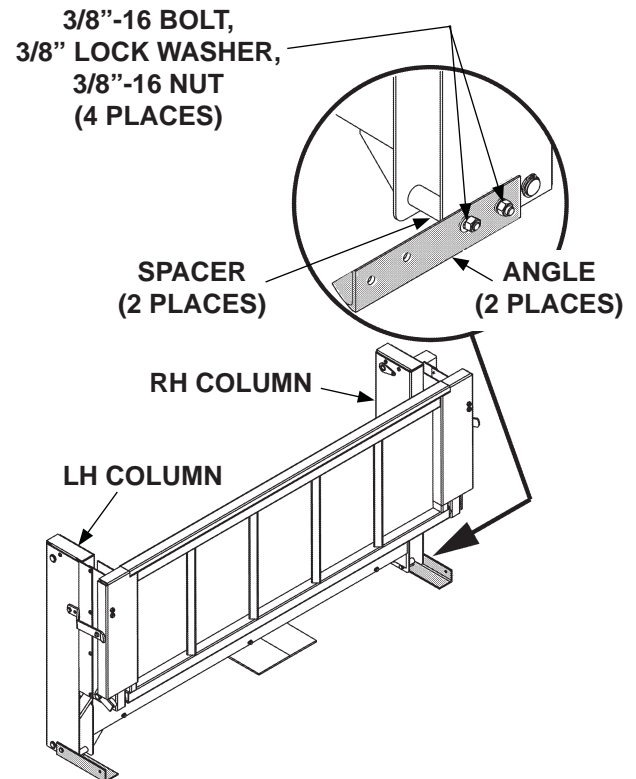

**REMOVING SHIPPING ANGLES BOLTED
TO COLUMNS OF C2 LIFTGATE
FIG. 6-1**

BOLTING ON MAIN FRAME BRACKETS

NOTE: The extra hole in the main frame mounting brackets is always below the 1/4" X 1" strip.

Bolt main frame mounting brackets (Kit items) to column flats (FIGS. 7-1 and 7-2).

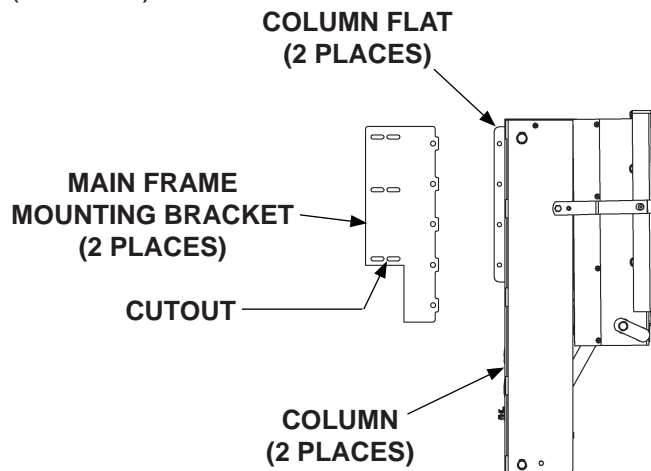

**C2 LIFTGATE SHOWN WITH BOLT-ON
MAIN FRAME BRACKETS**

FIG. 7-1

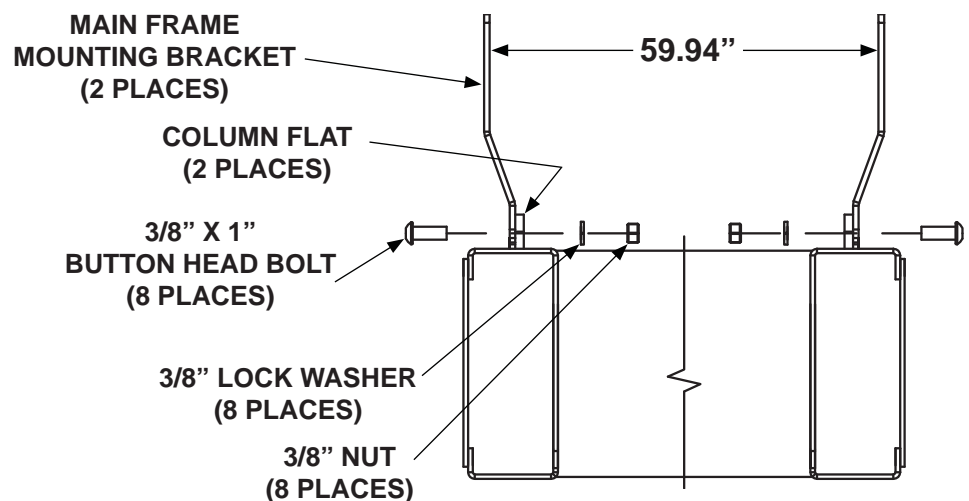

**BOLTING MAIN FRAME MOUNTING BRACKETS
TO COLUMNS ON C2 LIFTGATE
(TOP VIEW)**

FIG. 7-2

PREPARE TRUCK

NOTE: If tie down hooks are welded into body of truck, they do not need to be removed.

1. Unbolt tailgate, tailgate supports and tie-down hooks from pickup bed (**FIG. 8-1**). Save the fasteners.

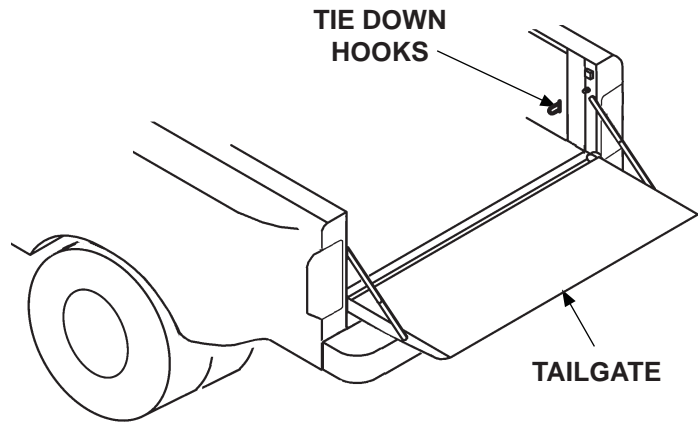

**REMOVING TAILGATE
AND TIE DOWN HOOKS
FIG. 8-1**

NOTE: The bumper and bumper mounting brackets cannot be reinstalled after liftgate is installed.

2. Unbolt and remove the rear bumper (**FIG. 8-2**).

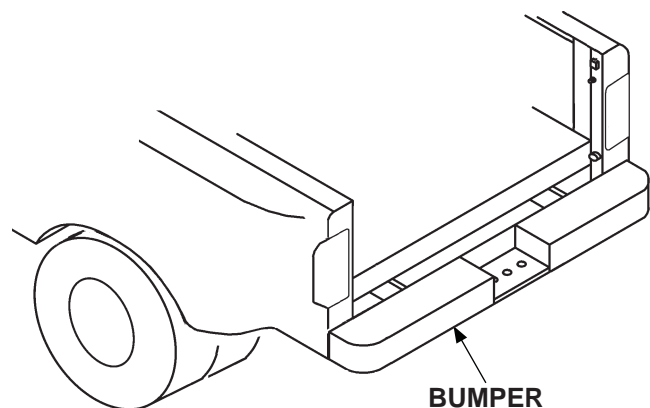

**REMOVING BUMPER
FIG. 8-2**

CHANGING TAILLIGHT MOUNTING FASTENERS

NOTE: To allow access to taillight bulbs after Liftgate is installed, changes to taillight mounting fasteners should be made before mounting Liftgate on pickup bed. If taillight fasteners are accessible through the main frame mounting brackets, it may not be necessary to change the taillight fasteners.

1. Remove 2 original taillight screws from RH taillight lens (**FIG. 9-1**). These screws are not needed after the taillight mounting is changed.
2. Drill a 9/64" hole through RH taillight lens and internal sheet metal (**FIG. 9-1**). Then, carefully drill a 3/16" hole through taillight lens to create clearance for the screw threads (**FIG. 9-1**).

NOTE: If liftgate is C2-15 model (1500 lb capacity), wait until liftgate is mounted on pickup bed before reinstalling taillights.

3. Apply clear automotive silicone sealant (**not supplied**) to the 3/16" hole in the taillight lens, and on the threaded portion of the self-tapping screw (**FIG. 9-1**).
4. Insert a self-tapping screw (Kit item) into 9/64" hole to secure the taillight lenses in place (**FIG 9-1**). Do not over-tighten screw.
5. Repeat steps 1 through 4 for LH taillight lens.

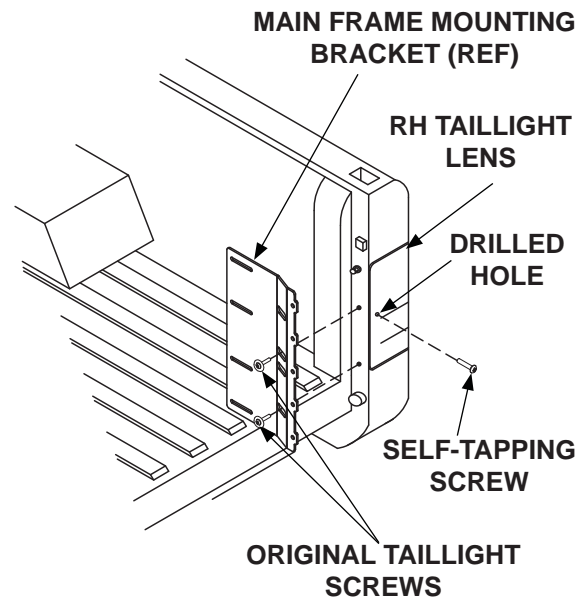

**MODIFYING TAILLIGHT MOUNTING
FIG. 9-1**

MODIFY SPARE TIRE ACCESS

NOTE: Modifying the spare tire crankhandle allows access to the spare tire hoist after the Liftgate is installed.

1. Remove the spare tire access grommet from crossmember under the pickup bed (FIG. 10-1).

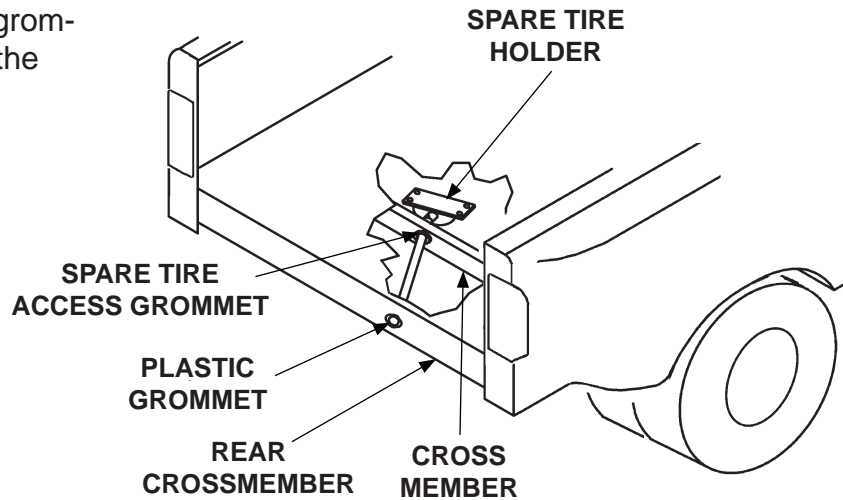

2. Remove plastic grommet from the rear crossmember of the truck frame (FIG. 10-1).

REMOVING GROMMETS FROM FRAME CROSSMEMBERS
FIG. 10-1

NOTE: Some trucks have a vibration damper that may interfere with the drilled hole. Remove damper if necessary.

3. Measure, mark, and drill 1-1/4" diameter hole above the existing spare tire access hole (FIG 10-2).

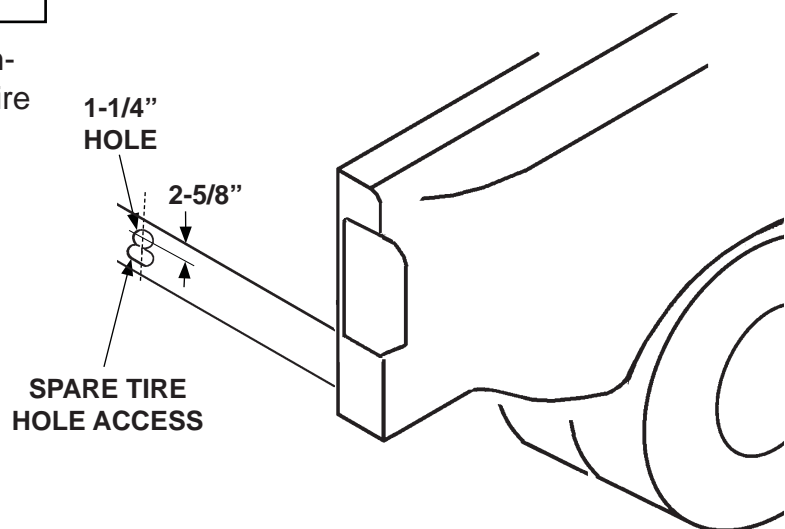

DRILLING HOLE FOR SPARE TIRE CRANK MECHANISM
FIG. 10-2

INSTALLING FILLER STRIP

⚠ WARNING

Recommended practices for welding on steel parts are contained in the current AWS (American Welding Society) D1.1 Structural Welding Code - Steel. Damage to Liftgate and/or vehicle, and personal injury can result from welds that are done incorrectly.

NOTE: If pickup truck is equipped with after-market hitch, weld filler strip to main frame housing. It will fill gap between liftgate and pickup bed.

1. Arrange the filler strips (Kit item) end-to-end as shown in **FIG. 11-1**.

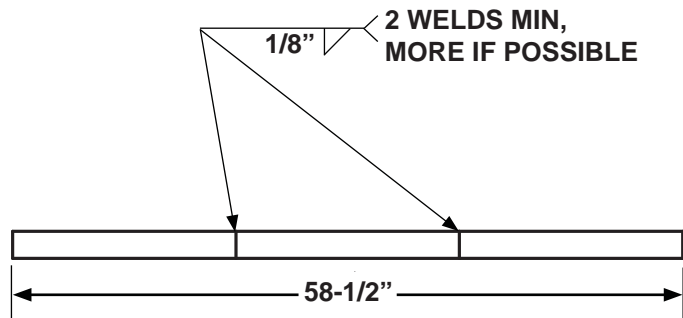

FILLER STRIPS LAYOUT & WELDING
FIG. 11-1

CAUTION

To prevent damage, liftgate bat-power cables are disconnected before using electrical welder. Put welder ground lead as close as possible to part being welded. Use protective cover on liftgate and truck body to protect from welding heat and spatter.

2. Butt the ends of the 3 filler strips together to make one long strip (**FIG. 11-1**). Then, weld the 3 strips together as shown in **FIG. 11-1**.

NOTE: Position filler strips with the welds facing down.

3. Position and support liftgate between the corner posts of pickup bed (**FIG. 11-2**). Next, position filler strip flush with top-rear edge of main frame housing. Then, weld filler strip to main frame (**FIG. 11-2**). When the welds are cool, filler strip can be painted.

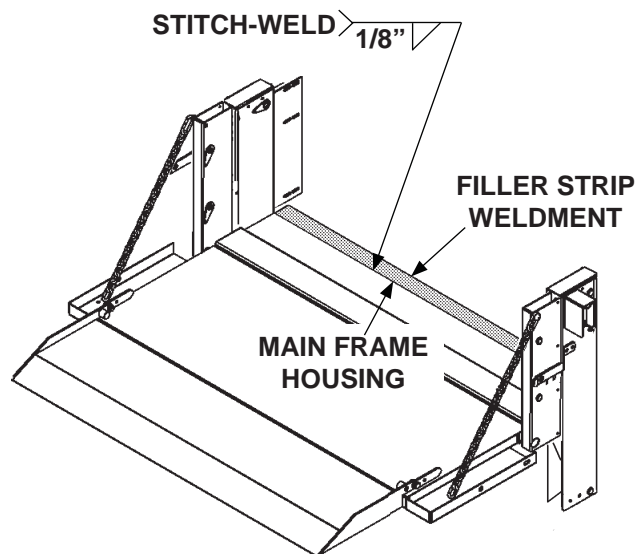

POSITIONING & WELDING FILLER STRIP
FIG. 11-2

REMOVE KNOCKOUTS

Verify which knockouts to remove from the bottom of main frame housing (**FIG. 12-1**). Then, remove the knockouts as needed.

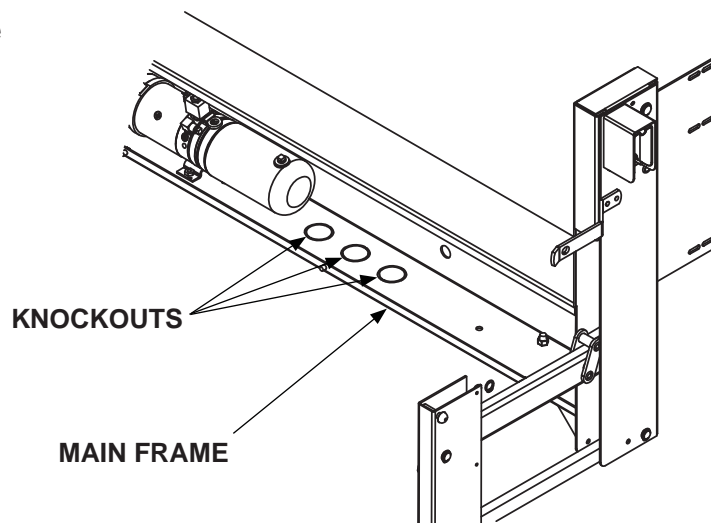

REMOVING KNOCKOUTS FROM MAIN FRAME
FIG. 12-1

INSTALLING LIFTGATE

1. Bolt a reinforcement angle (Kit item) to RH and LH mounting brackets (Kit items) as shown in **FIG. 13-1**.

NOTE: Holes for mounting brackets are marked and drilled only after liftgate is in correct position on the pickup bed.

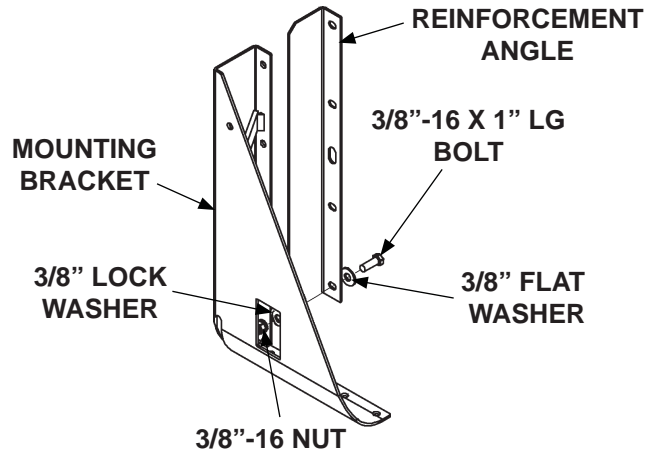

**BOLTING REINFORCEMENT ANGLE TO MOUNTING BRACKET
FIG. 13-1**

2. Position the LH and RH mounting brackets (Kit items) in the pickup bed just forward of corner posts (**FIG. 13-2**).

3. Position liftgate in the rear opening of the pickup bed (**FIG. 13-2**).

- Liftgate centered on rear opening in pickup bed
- Columns vertical
- Spare tire access hole aligned with spare tire tube on truck
- Top of main frame flush with floor of pickup bed

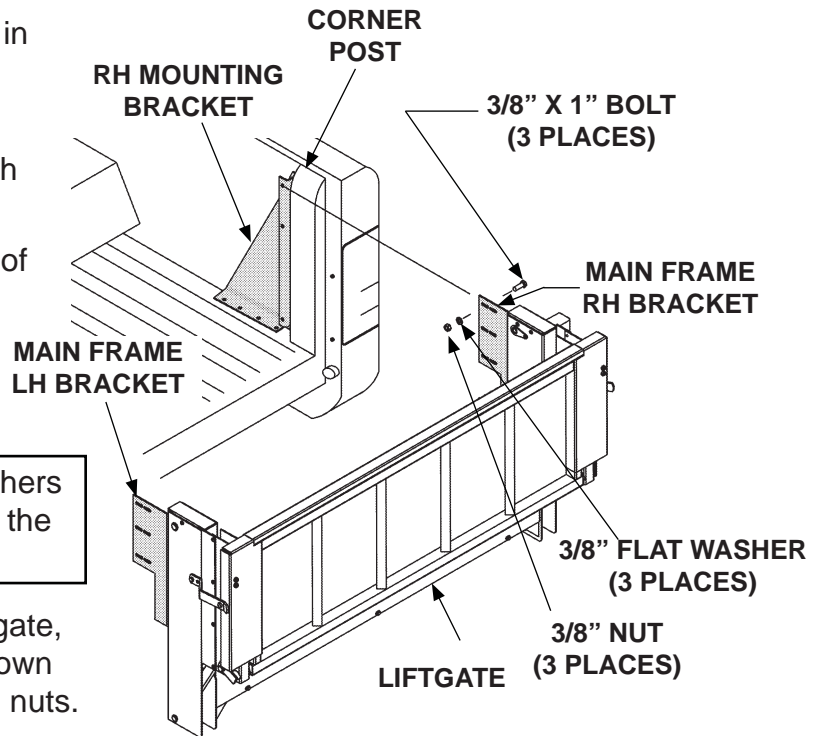

NOTE: Ensure nuts and lock washers are on the inboard side of the mounting brackets.

4. Bolt the main frame brackets on liftgate, to the RH mounting brackets as shown in **FIG. 13-2**. Handtighten bolts and nuts. Repeat for LH mounting bracket.

5. Let liftgate hang, in the rear opening of pickup bed, with support from corner posts.

**BOLTING LIFTGATE TO RH MOUNTING BRACKET
FIG. 13-2**

INSTALL LIFTGATE - Continued

6. Hold the RH mounting bracket against the corner post. Then, drill two 3/8" holes into truck bed floor using two holes in bracket as a guide (**FIG. 14-1**). Repeat Step 5 for LH mounting bracket.
7. Fasten each bracket to the pickup bed with the hex head bolts (Kit item). Then, fasten the lock washers (Kit item) and hex nuts (Kit item) to the back plate (Kit item) under the pickup bed (**FIG. 14-1**).
8. Adjust Liftgate so platform is level from front to back. Then, tighten bolts securing the main frame mounting brackets to the RH and LH mounting brackets (**FIG. 13-1**).

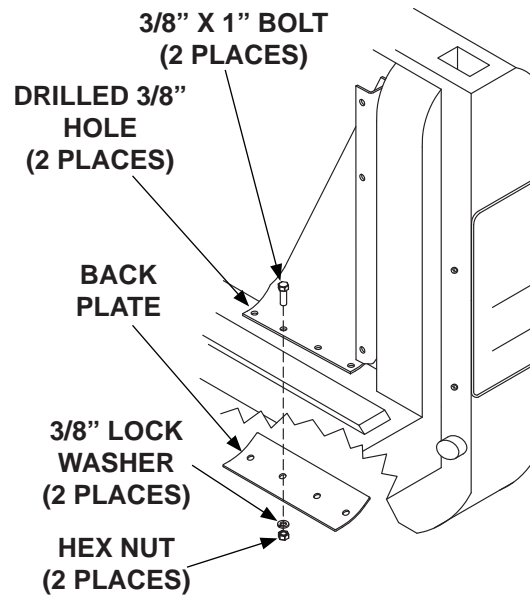

**FASTENING BRACKET AND BACK PLATE TO
TRUCK BED (RH SIDE SHOWN)**
FIG. 14-1

ADD ADDITIONAL SUPPORT

1. Locate the existing 3/8" hole in the RH mounting bracket (**FIG. 14-2**).
2. Mark and drill a 3/8" hole in the inner side of the pickup bed using the RH mounting bracket hole as a guide (**FIG. 14-2**).
3. Fasten the RH mounting bracket to the inner side of pickup bed with the lock washer (Kit item) and nut (Kit item) on the bracket side. Then, fasten the hex head bolt (Kit item) and flat washer on the truck side (**FIG. 14-2**).
4. Repeat Steps 1 through 3 for the LH mounting bracket.
5. Install taillight lenses.

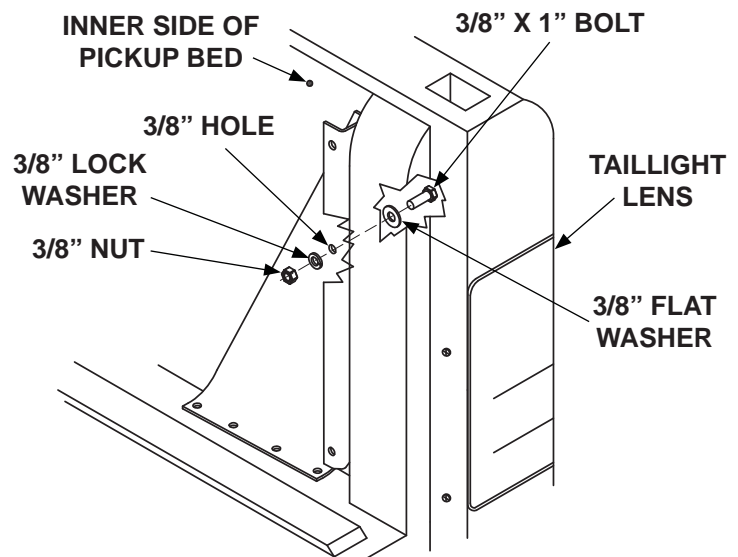

**FASTENING BRACKET TO PICKUP BED
(RIGHT SIDE SHOWN)**
FIG. 14-2

CHECK SPARE TIRE ACCESS

CAUTION

Do not use a battery charger for connecting power to Liftgate power cables.

1. Connect power from a 12 volt truck battery to the Liftgate power cables extending from the back of main frame housing.
2. Refer to operating instructions, in **C2 Operation Manual**, to unfold platform and activate the Liftgate.

NOTE: With the **POWER ON** and **LIFTGATE ACTIVATED** lights on, the Liftgate can be raised or lowered. If the Liftgate is not used for 90 seconds, the control will automatically deactivate.

3. Use the control switch to lower (**DN**) the platform to the ground (**FIG. 15-1**).
4. Unbolt and remove cover from main frame housing (**FIG. 15-2**).

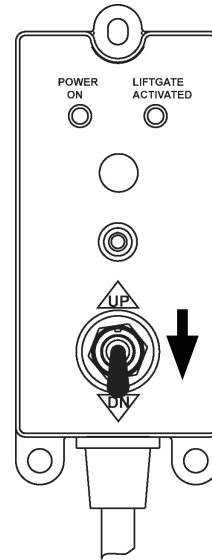

**USING CONTROL SWITCH TO LOWER LIFTGATE
FIG. 15-1**

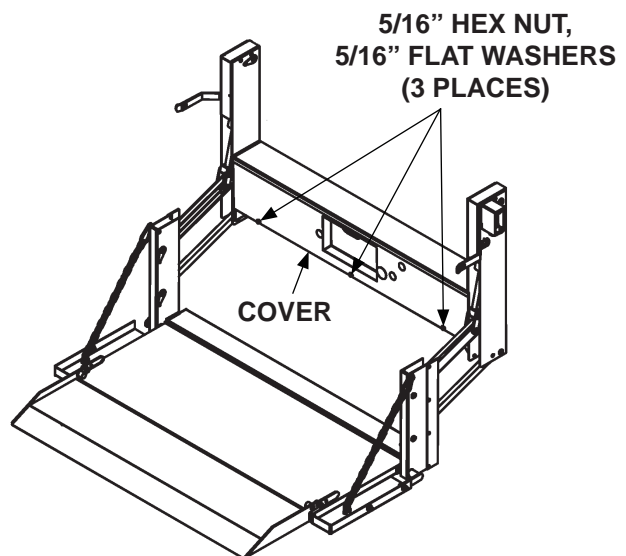

**REMOVING HOUSING COVER FROM C2 LIFTGATE
FIG. 15-2**

CHECKING ACCESS TO SPARE TIRE - Continued

- 5. Remove the correct black plastic plugs from the cover and mainframe (FIG. 16-1).

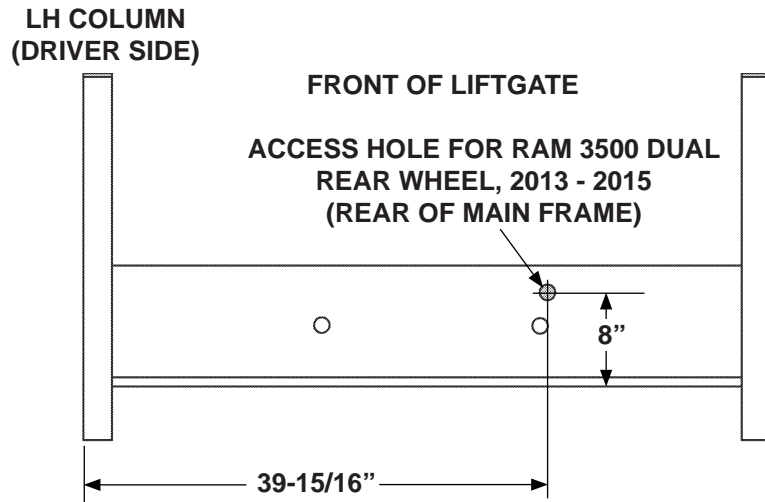

- 6. Insert the spare tire crank handle through the holes in the liftgate main frame.

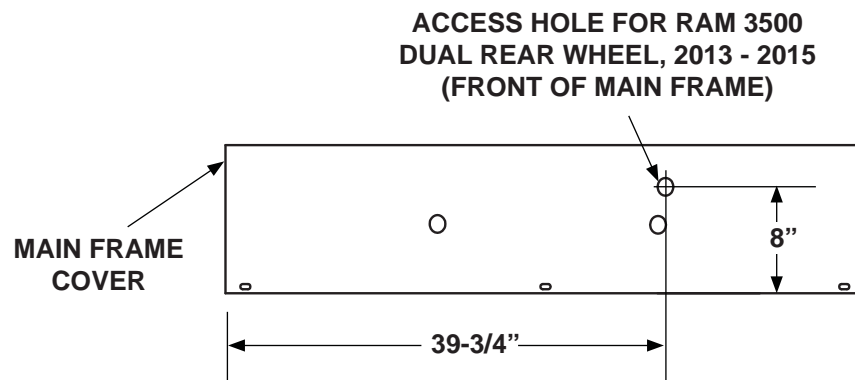

REMOVING PLASTIC PLUGS FOR SPARE TIRE ACCESS, RAM 3500 DUAL REAR WHEEL PICKUP FIG. 16-1

- 7. Ensure spare tire can be accessed using the crank handle.

ROUTING POWER CABLES

1. Remove the small parts and manual kit from the main frame housing. Refer to **Sheet 4** for contents of the kits.
2. Install circuit breaker (**FIG. 17-1**) inside the engine compartment near truck battery (+) terminal and away from moving parts. Allow enough room for power cables to be run and for easy access to circuit breaker.

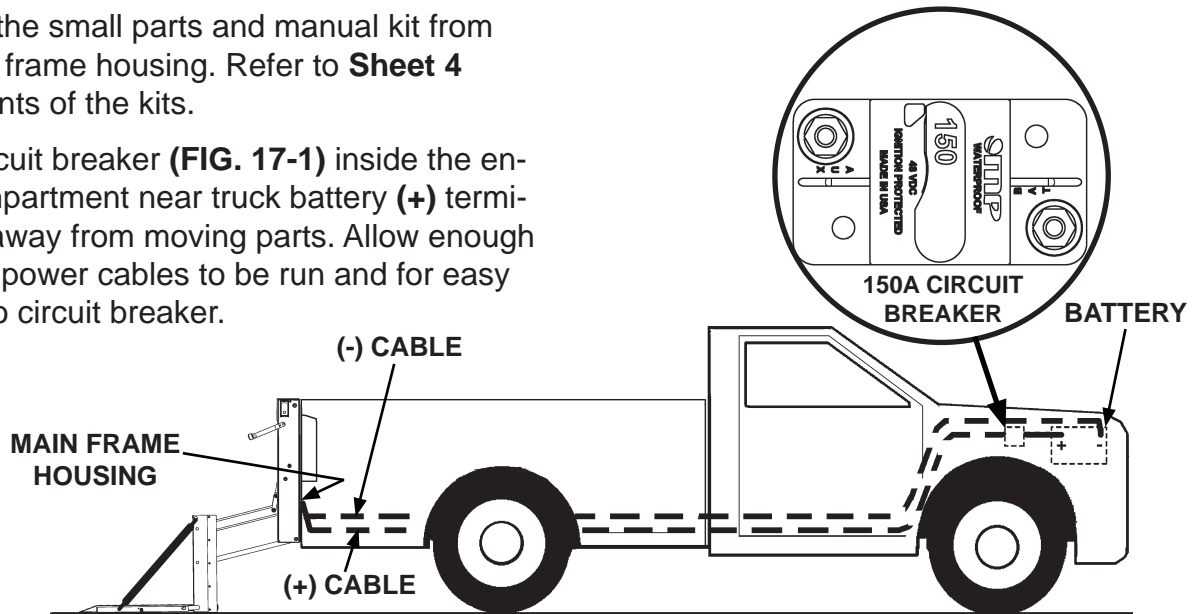

RUNNING POWER CABLES FROM LIFTGATE TO BATTERY

FIG. 17-1

3. Pull the (+) and (-) power cables through the cord grip on back of main frame housing. Leave about 2" of slack, for power cables, inside main frame housing.
4. Route power cables along truck frame to truck battery (**FIG. 17-1**). Pull extra cable beyond the battery terminals. Then, separate positive (+) cable from negative (-) cable.
5. Cut positive (+) cable to the length required to reach the **AUX** terminal of the circuit breaker (**FIG. 17-1**), without putting strain on the connection. Install copper lug (Kit item) (**FIGS. 17-2 and 17-3**). Then, connect to **AUX** terminal on 150A circuit breaker.

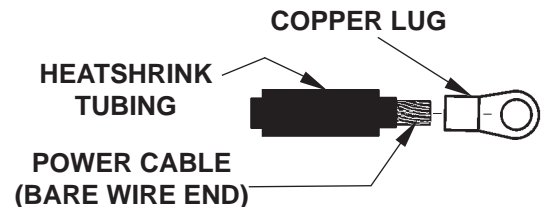

PLACING COPPER LUG & HEATSHRINK TUBING ON POWER CABLE

FIG. 17-2

6. Cut remaining positive (+) cable long enough to reach from the circuit breaker **BAT** terminal to the positive (+) battery terminal (**FIG. 17-1**) without putting strain on the connection. Install copper lugs (Kit item) on both ends of cable (**FIGS. 17-2 and 17-3**). Then, connect cable to **BAT** terminal on 150A circuit breaker and positive (+) terminal on battery.



TYPICAL POWER CABLE WITH COPPER LUG INSTALLED

FIG. 17-3

7. Cut negative (-) cable to length required to reach negative (-) battery terminal without putting strain on the connection. Install copper lug (Kit item) (**FIGS. 17-2 and 17-3**). Then, connect cable to negative (-) terminal on battery.

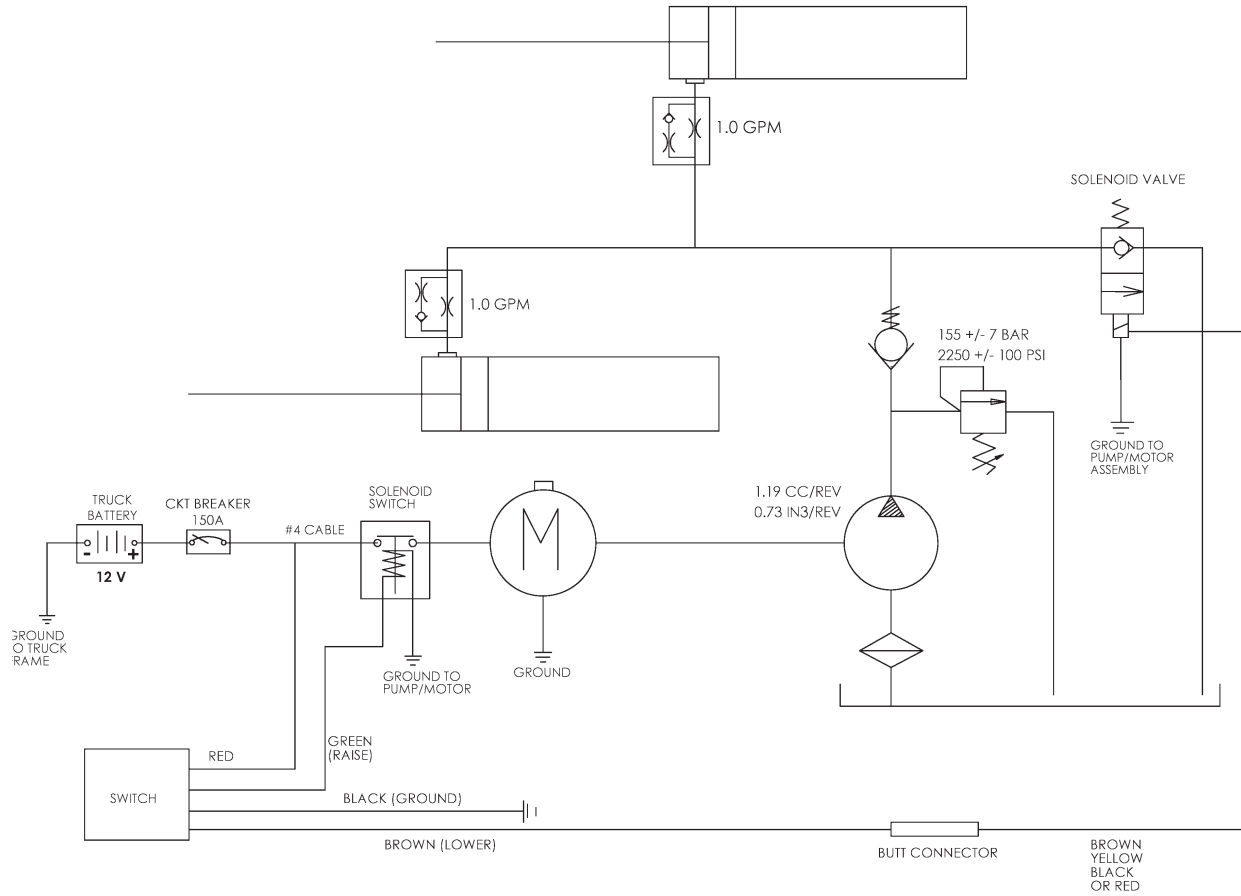

C2 PICKUP LIFTGATE HYDRAULIC & ELECTRICAL SYSTEMS DIAGRAM
FIG. 18-1

INSTALL LOWER MOUNT ON CLASS 4 OR CLASS 5 HITCH

NOTE: Lower mounts are essential for Liftgate to be installed correctly. They attach to the trailer hitch and support the bottom of Liftgate.

1. For Class 4 hitch, install washer plate (Kit item) through center hole in the bottom of Liftgate mainframe and center hole in the factory hitch plate on the truck (**FIG. 19-1**). For Class 5 hitch, install washer plate (Kit item) through the outer two holes in the bottom of Liftgate mainframe and the two holes in the factory hitch plate on the truck (**FIG. 19-2**).

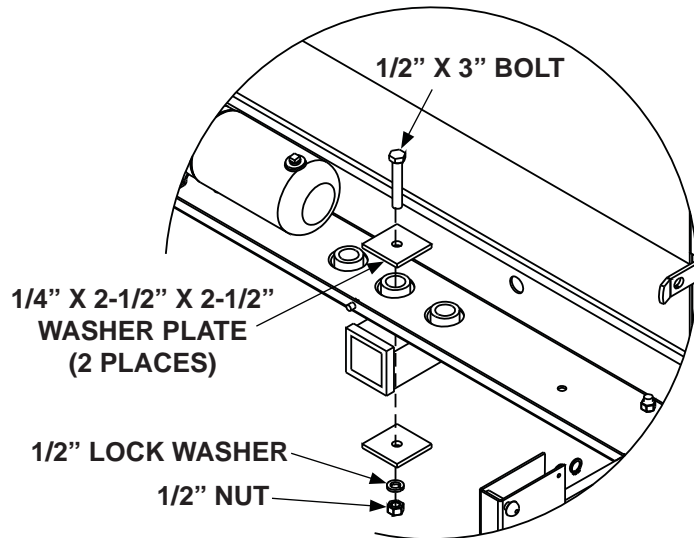

INSTALLING WASHER PLATE ON CLASS 4 HITCH
FIG. 19-1

2. If needed, install bracket plates (Kit item) between Liftgate and factory hitch plate to raise the top of the Liftgate to bed height (**FIG. 19-2**).

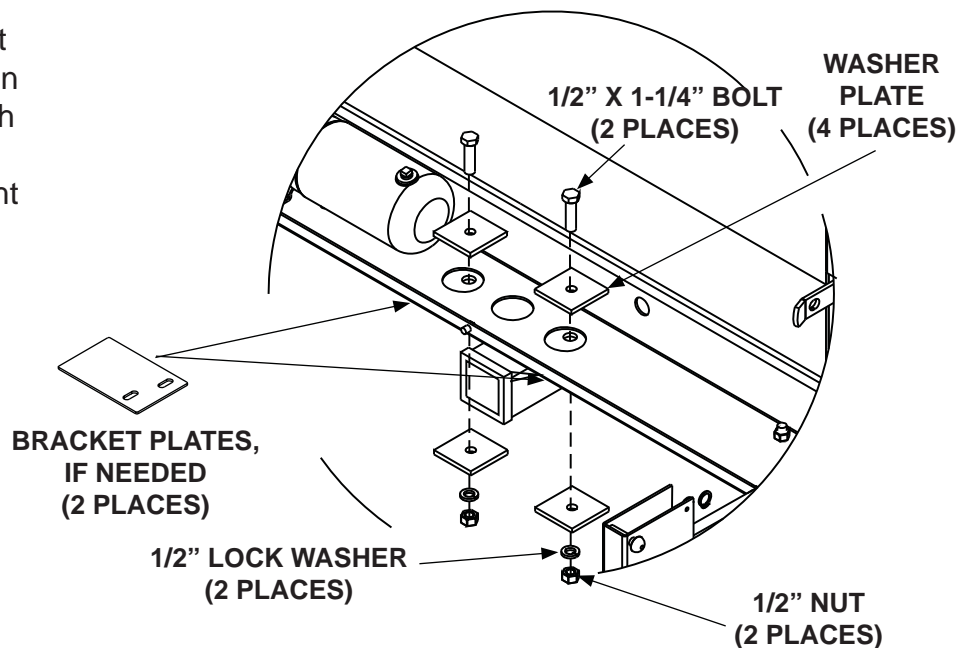

INSTALLING WASHER PLATE ON CLASS 5 HITCH
FIG. 19-2

COMPLETE LIFTGATE INSTALLATION

CAUTION

Hydraulic system is filled at the factory with correct amount of oil. It is unnecessary to add more oil except as required for periodic maintenance of the liftgate.

1. Remove the solid plug from the pump reservoir (**FIG. 20-1**). Install breather plug (Kit item) in pump reservoir.

2. Bolt on main frame cover (**FIG. 20-2**).

3. Install the two square plastic grommet nuts (Kit item), for the license plate, into the square holes on the Liftgate main frame cover (**FIG. 20-2**).

4. Install the license plate using two 1/4"-20 self-tapping screws (Kit item) (**FIG. 20-2**).

5. Install the license plate lights into the holes provided. Refer to instruction sheet **M-14-35**. Then, connect the license plate lights to the vehicle's wiring.

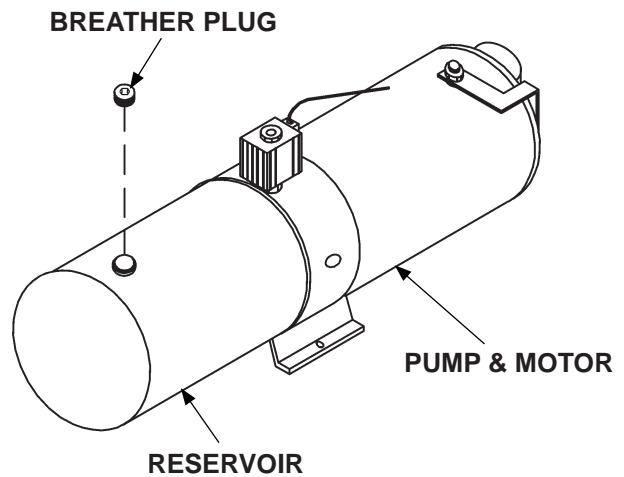

INSTALLING VENT PLUG ON
PUMP RESERVOIR
FIG. 20-1

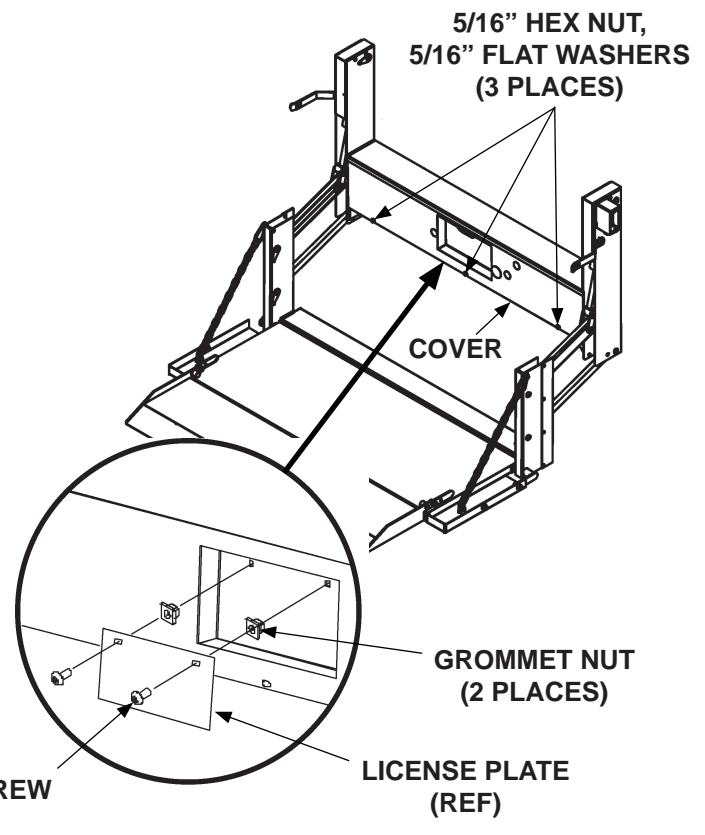

INSTALLING COVER & LICENSE PLATE
(C2 LIFTGATE SHOWN)
FIG. 20-2

COMPLETE LIFTGATE INSTALLATION - Continued

6. To use the drop-away platform feature, install drop pin and 3/8"-16 lock nut (Kit items) on the bottom of RH column (FIG. 21-1). Tighten lock nut securely.

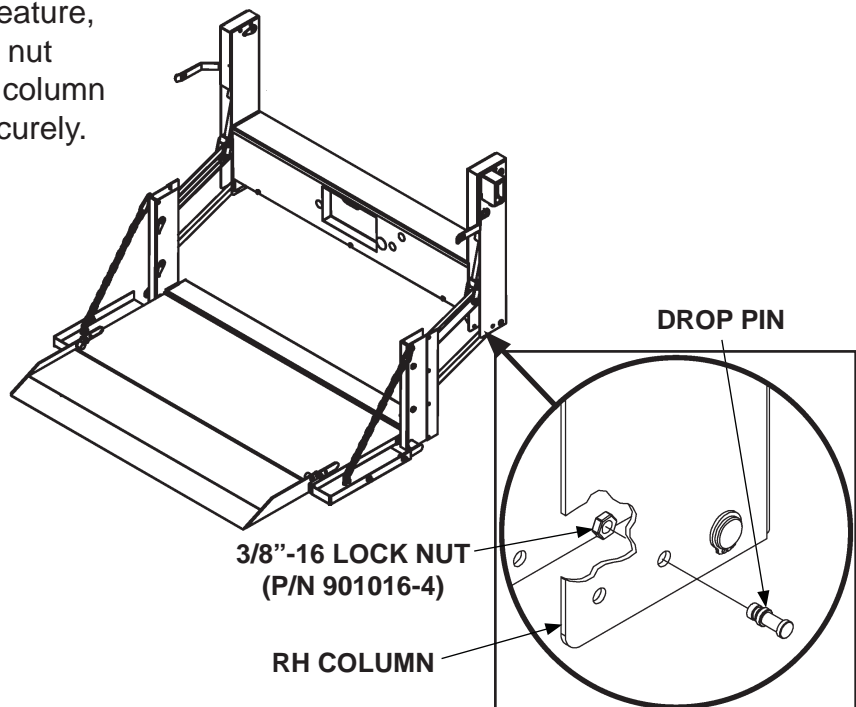

**INSTALLING DROP PIN ON
RH COLUMN (C2 LIFTGATE SHOWN)
FIG. 21-1**

7. Install the 3/8" round plastic plugs into the empty holes in the bottom of the columns.
8. If previously removed, reinstall spare tire.

TEST OPERATION OF LIFTGATE

! WARNING

Keep all foreign objects out of the Liftgate mainframe and away from pinch points at all times when operating Liftgate.

NOTE: The **LIFTGATE ACTIVATED** LED illuminates when Liftgate power is on. Control switch should deactivate after 90 seconds of not being used.

1. Check operation of control switch for proper operation by pressing **POWER ON** button once to activate. Next, press **POWER ON** button again to deactivate Liftgate power. Then, press the **POWER ON** button twice to reset low voltage (**FIG. 22-1**).
2. Press the **LIFTGATE ACTIVATED** switch within 1 second to activate the timer (**FIG. 22-1**).
3. Raise (**UP**) and lower (**DN**) the unloaded platform (**FIGS. 22-1** and **22-2**) on a flat surface. Check for proper operating speed and alignment with the ground.
4. Load the platform with the rated capacity and measure the time to **RAISE** the platform (**FIG. 22-1**). The platform should raise approximately 2" to 3" per second.
5. Examine the platform for any downward creep.
6. Measure the time to **LOWER** the platform still loaded (**FIG. 22-2**). The load should descend approximately 7" to 9" per second.
7. Remove the load from the platform and examine the Liftgate and vehicle for hydraulic oil leaks, loose wiring, and any other problems.
8. Reinstall the main frame housing cover. Then, close and latch platform.

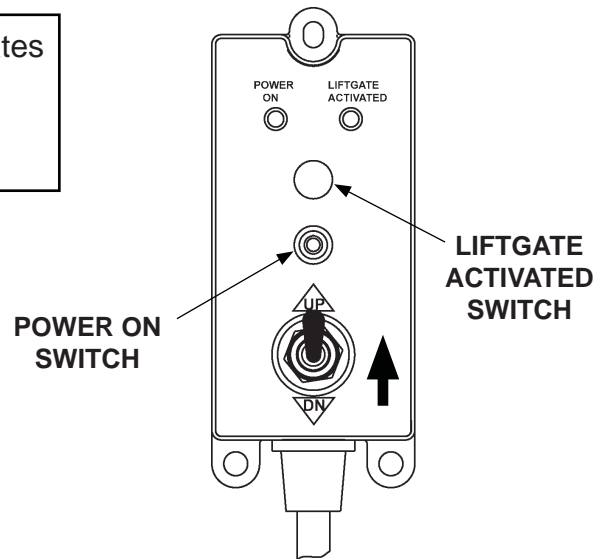

CHECKING OPERATION OF CONTROL SWITCH AND RAISING PLATFORM
FIG. 22-1

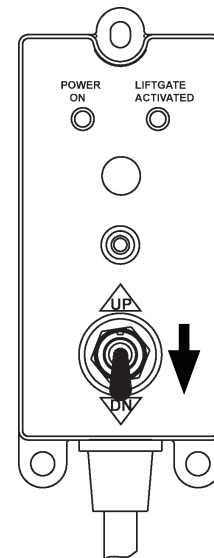

USING CONTROL SWITCH TO LOWER PLATFORM
FIG. 22-2

TEST OPERATION OF LIFTGATE - Continued

9. Lock the latch on LH side or RH side through the hole in the latch pin (FIG. 23-1).

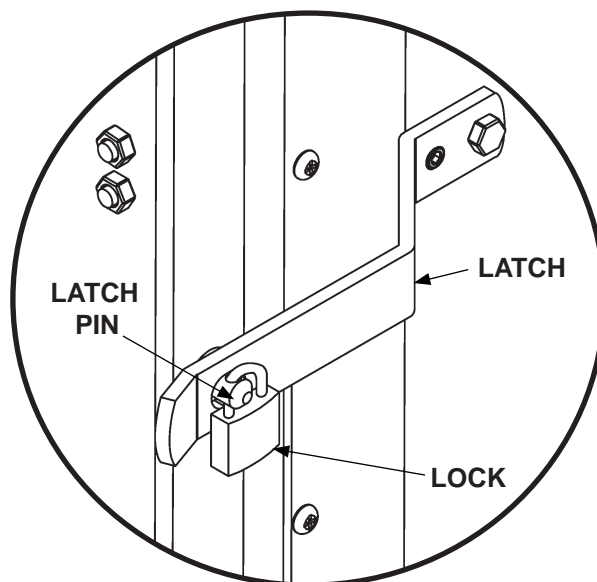

**LOCKING PLATFORM
(C2 LIFTGATE)
FIG. 23-1**