

INSTRUCTIONS, (FORD) SUPER DUTY INSTALLATION KIT (C2 PICKUP LIFTGATES)

FORD SUPER DUTY F-250, F-350 & F-450 PICKUP TRUCKS,
2017 MODEL

KIT P/N 297890-01 (T-285)

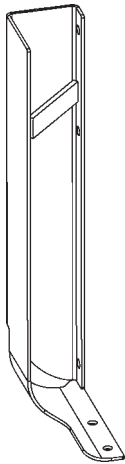

MOUNTING BRACKET, LH
P/N 297885-01
QTY. 1

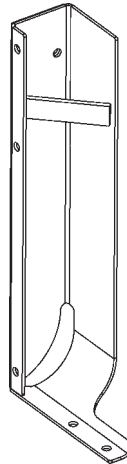

MOUNTING BRACKET, RH
P/N 297885-02
QTY. 1

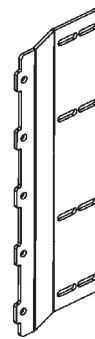

**MAIN FRAME
MOUNTING BRACKET**
P/N 297887-01
QTY. 2

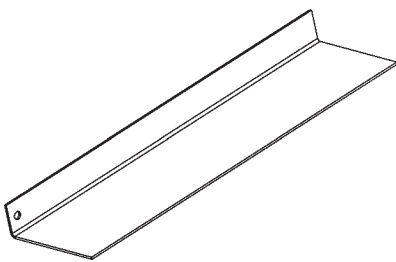

FILLER PLATE, 19-1/2' LG
P/N 297888-01
QTY. 3

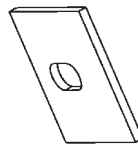

SPACER, 1/8" X 2" X 2"
P/N 295991-01
QTY. 6

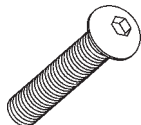

VINYL PROTECTION TAPE
(2" WIDE X 144" LG)
P/N 297838-01
QTY. 1

BOLT KIT, P/N 289488-01

BUTTONHEAD SCREW
3/8"- 16 X 1" LG.
P/N 900064-05
QTY. 8



PAN HEAD SCREW
#10-24 X 3/4" LG.
P/N 900753-07
QTY. 8

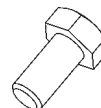

HEX CAP SCREW
3/16"-16 X 1" LG, GR5
P/N 900778-02
QTY. 12



LOCK WASHER, 3/8"
P/N 902011-4
QTY. 20



LOCK WASHER, 1/2"
P/N 902011-6
QTY. 6

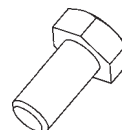

HEX CAP SCREW
1/2"- 13 X 1-1/4" LG, GR5
P/N 900781-02
QTY. 6



FLAT WASHER, 3/8"
P/N 902001-2
QTY. 6

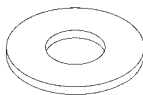

FLAT WASHER,
1-3/8" OD, 1/2"
P/N 902014
QTY. 4

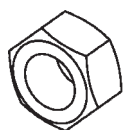

HEX NUT, 3/8"-16
P/N 903161-05
QTY. 20

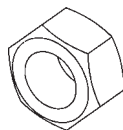

LOCK NUT, 1/2"-13
P/N 040066
QTY. 4

CIRCUIT BREAKER MOUNTING KIT P/N 295999-01 (014196)

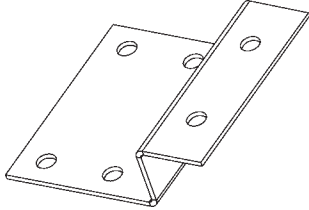

CIRCUIT BREAKER BRACKET
P/N 295998-01
QTY. 1



**HEX HEAD SELF-DRILLING
SCREW, #12 X 3/4" LG.**
P/N 900045-1
QTY. 2



PAN HEAD SCREW,
1/4"-20 X 3/4" LG.
P/N 900002-1
QTY. 2



NUT, 1/4"-20
P/N 903163-01
QTY. 2

BOLT KIT (BAGGED), P/N 297891-01 (13180)



**HEX HEAD SELF-DRILLING
SCREW, #12 X 3/4" LG.**
P/N 900045-1
QTY. 12

NOTE: C2 Liftgates are shipped with the following parts kits for installing the Liftgate.
The parts are stored in the main frame housing.

C2 LIFTGATE SMALL PARTS & MANUAL KIT P/N 289484-01

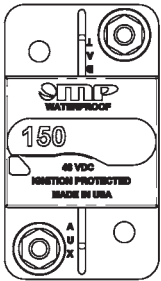

**CIRCUIT BREAKER,
150 AMP
P/N 907207-01
QTY. 1**



**LICENSE PLATE
LIGHT
P/N 907210-01
QTY. 1**

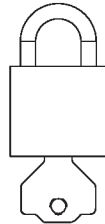

**PADLOCK (2 KEYS)
P/N 908221-01
QTY. 1**

LICENSE
PLATE LIGHT
INSTALLATION
M-14-35

C2
OPERATION
MANUAL
M-14-36



**NYLON PLUG, 1/2"
P/N 908081-01
QTY. 5**

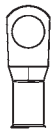

**LUG, 4GA
COPPER, 3/8"
P/N 907278-01
QTY. 4**



**BUTT CONNECTOR,
14-16 AWG
P/N 030491
QTY. 2**



**SELF-TAPPING SCREW,
1/4"-20 X 5/8" LG.
P/N 900705-02
QTY. 2**



**PAN HEAD SCREW,
#10-24 X 3/4" LG.
P/N 900007-6
QTY. 2**



**DROP-AWAY PIN
P/N 289483-01
QTY. 1**



**GROMMET NUT, 1/4"
P/N 901015-03
QTY. 2**



**NUT, #10-24
P/N 903163-02
QTY. 2**



**LOCK NUT, 3/8"-16
P/N 901016-4
QTY. 1**

BREATHER (PUMP RESERVOIR)



**BREATHER PLUG, 3/8" NPT
P/N 295049
QTY. 1**

LOWER MOUNTING ANGLE

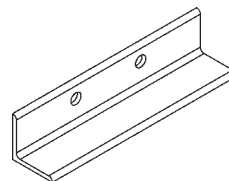

**SHIPPING LEG
P/N 289543-02
QTY. 2**

NOTE: Installer is responsible for ensuring vehicle meets Federal, State, and Local standards and regulations.

BODY STRENGTH

⚠ WARNING

Consult vehicle body manufacturer for vehicle body strength data. Make sure the forces created by the Liftgate are within the limits prescribed by the vehicle body manufacturer.

NOTE: Maximum operating bed height for **C2** mounted on pickup body is **42" (Unloaded)**. Minimum bed height is **28" (Loaded)**.

The **C2** is a body-mounted liftgate that put forces on the side walls of truck bodies (**FIG. 5-1**). For correct installation, truck bodies must be strong enough to withstand the tension, compression and shear forces shown in **FIG. 5-1**.

- X= Tension on each sidewall**
- Y= Compression on each sidewall**
- Z= Shear on each sidewall**

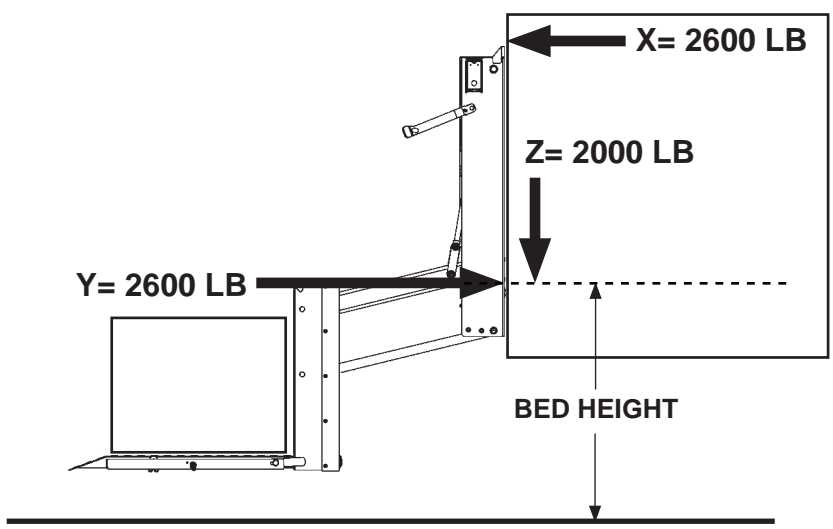

**C2 LIFTGATE SHOWN ON TRUCK BODY
FIG. 5-1**

PREPARING LIFTGATE

1. Remove mounting kits shipped with liftgate.
Refer to **Sheets 1, 2, 3, and 4**. Verify mounting brackets are the correct brackets for this installation.

⚠ CAUTION

Liftgate will not stand upright without the shipping angles. Before removing the angles, make sure Liftgate is supported with forklift or pallet jack. Injury & property damage could result if Liftgate falls over.

2. Support Liftgate on shipping pallet with forklift or pallet jack. Then, unbolt shipping angle from each column on the Liftgate (**FIG. 6-1**). Save shipping angles to use for lower mounting brackets.

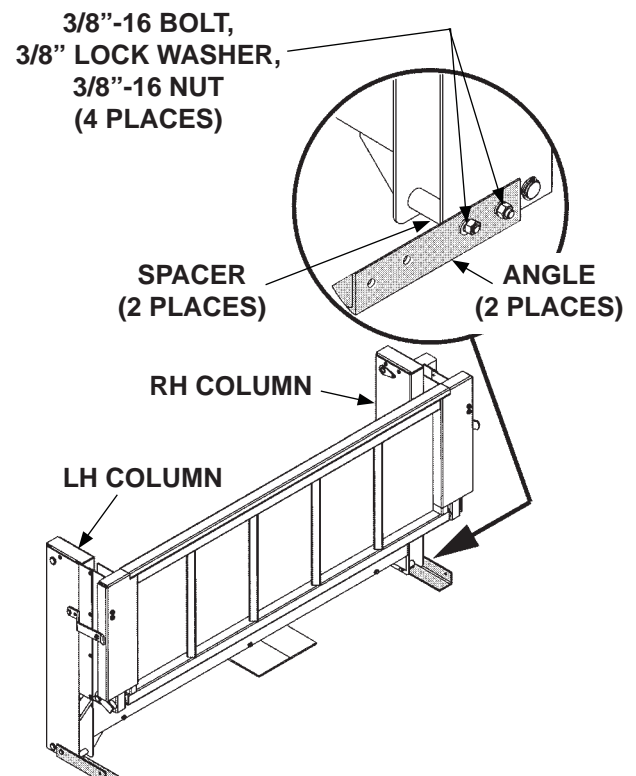

**REMOVING SHIPPING ANGLES BOLTED
TO COLUMNS OF C2 LIFTGATE
FIG. 6-1**

BOLTING ON MAIN FRAME BRACKETS

NOTE: The extra hole in the main frame mounting brackets is always below the 1/4" X 1" strip.

Bolt main frame mounting brackets (Kit items) to column flats (**FIGS. 7-1 and 7-2**).

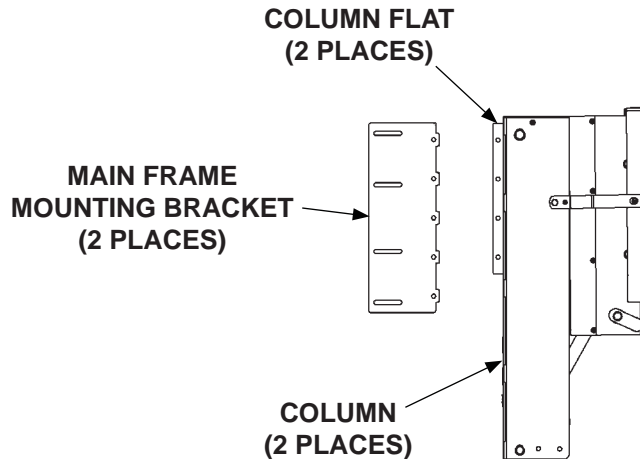

**C2 LIFTGATE SHOWN WITH BOLT-ON
MAIN FRAME BRACKETS
FIG. 7-1**

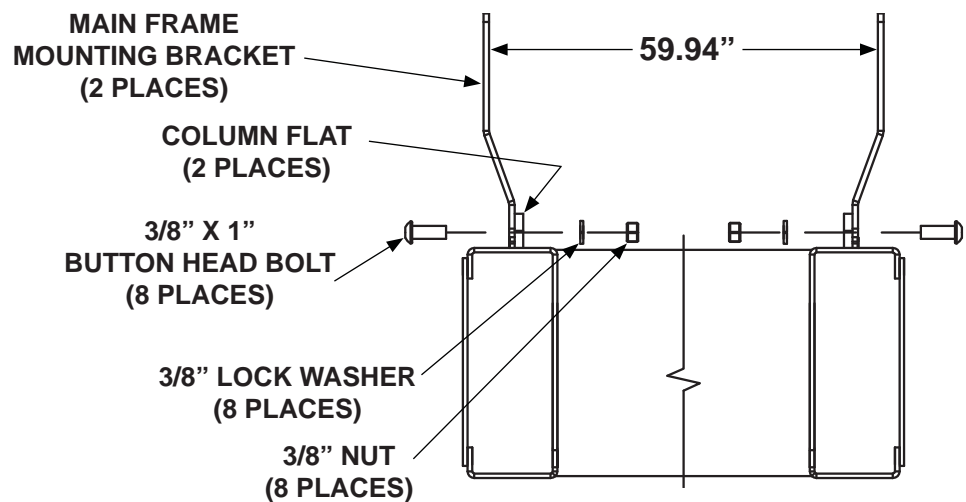

**BOLTING MAIN FRAME MOUNTING BRACKETS
TO OUTSIDE OF COLUMNS ON C2 LIFTGATE
(TOP VIEW)
FIG. 7-2**

PREPARING PICKUP TRUCK

NOTE: Keep the OEM trailer hitch on the truck. It is not necessary to remove the hitch. Liftgate can be mounted 4" to 5" away from the pickup bed to allow sufficient clearance for the hitch.

1. Unbolt the tailgate and supports (FIG. 8-1).

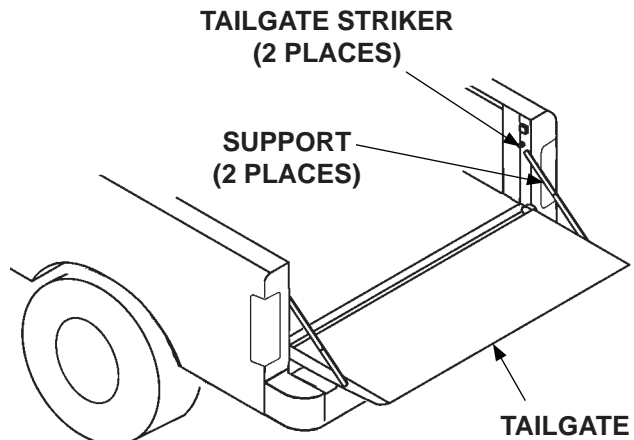

REMOVING TAILGATE & SUPPORTS
FIG. 8-1

2. Remove the tailgate strikers and any other tailgate hardware from the rear of the pickup bed (FIG. 8-1).

3. Support rear bumper (FIG. 8-2) before unbolting the bumper brackets.

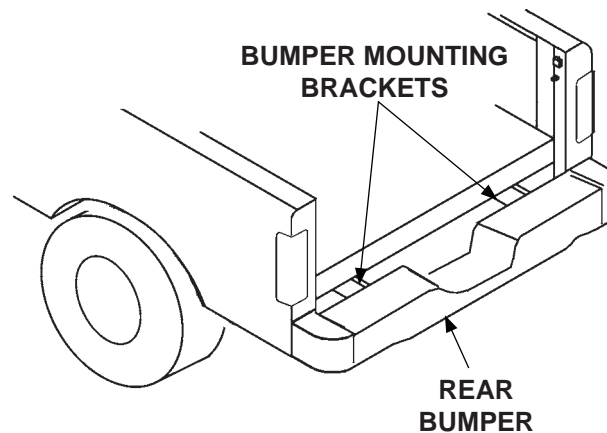

REMOVING REAR BUMPER
FIG. 8-2

NOTE: When liftgate is installed on the truck the tailgate and rear bumper cannot be reinstalled.

4. Unbolt and remove rear bumper, bumper brackets (FIG. 8-2).

PREPARING PICKUP TRUCK - TAILLIGHT MOUNTING

NOTE: No changes are necessary for OEM taillight fasteners. The taillight mounting screws can be removed with an 8mm wrench after liftgate is installed.

INSTALLING FILLER STRIP

NOTE: The filler strips in the kit will bridge the gap between liftgate and pickup bed. It is important to fasten the filler strips to Liftgate before installing the Liftgate on the truck.

1. Butt the 3 filler strips (Kit item) end-to-end to make 1 long strip at the top rear edge of the main frame housing (**FIG. 9-1**). Position each strip so the short flange and screw hole is butted against the back of the housing (**FIG. 9-1**). Ensure the top surface of each filler strip is flush with top surface the housing.

CAUTION

Before drilling holes in the main frame housing, ensure there are no obstructions to drill bit or no items that could be damaged by drill bit.

2. Use each filler strip as a template to mark and drill hole in back of the main frame housing (**FIG. 9-1**).
3. Fasten each filler strip to main frame with a #12 x 3/4" long self-drilling screw (bagged bolts) (**FIG. 9-1**).

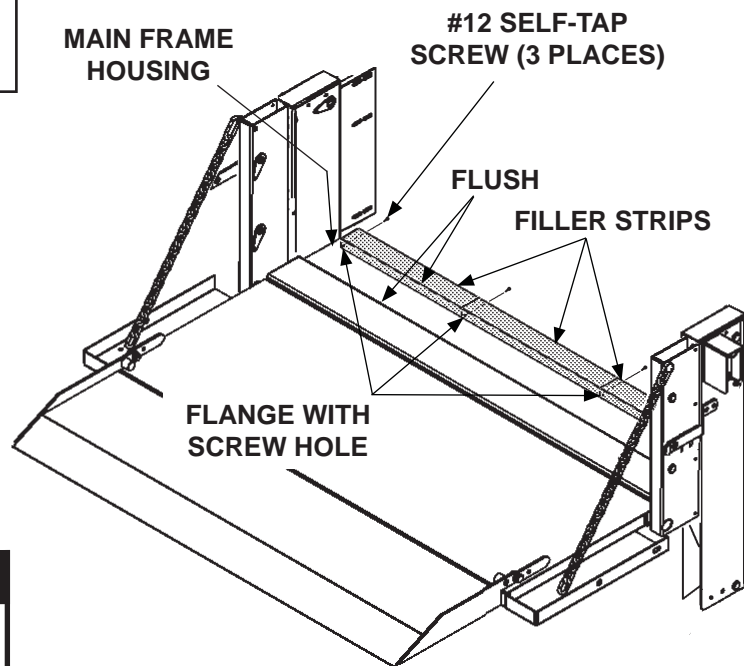

POSITIONING FILLER STRIPS
FIG. 9-1

INSTALLING LIFTGATE

CAUTION

Galvanic corrosion may occur if steel filler strips & brackets are in contact with aluminum truck body. Use vinyl tape from this kit to separate the filler strips & brackets from truck body.

NOTE: Tape RH & LH mounting brackets before bolting to vehicle.

1. Place strips of electrical tape (Kit item) on RH and LH mounting brackets as shown in **FIG. 10-1**. Then, apply strips of electrical tape (19-1/2" long) under the filler strips on main frame housing (**FIG. 9-1**).

NOTE: Holes for mounting brackets are marked and drilled only after liftgate is in correct position on the pickup bed.

2. Position the LH and RH mounting brackets (Kit items) in the pickup bed just forward of corner posts (**FIG. 10-2**).
3. Position liftgate in the rear opening of the pickup bed (**FIG. 10-2**).
 - Liftgate centered on rear opening in pickup bed
 - Columns vertical
 - Spare tire access hole aligned with spare tire tube on truck
 - Top of main frame and filler strip flush with floor of pickup bed

NOTE: Ensure nuts and lock washers are on the inboard side of the mounting brackets.

4. Bolt the main frame brackets on liftgate, to the RH mounting brackets as shown in **FIG. 10-2**. Handtighten bolts and nuts. Repeat for LH mounting bracket.

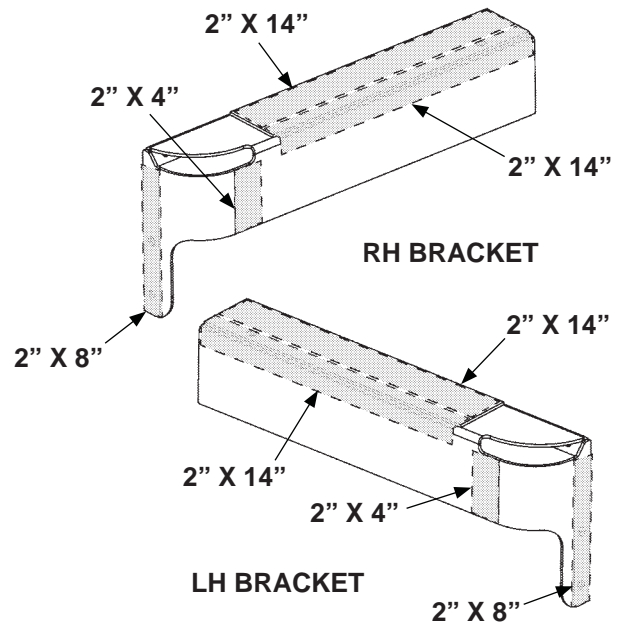

TAPING MOUNTING BRACKETS
FIG. 10-1

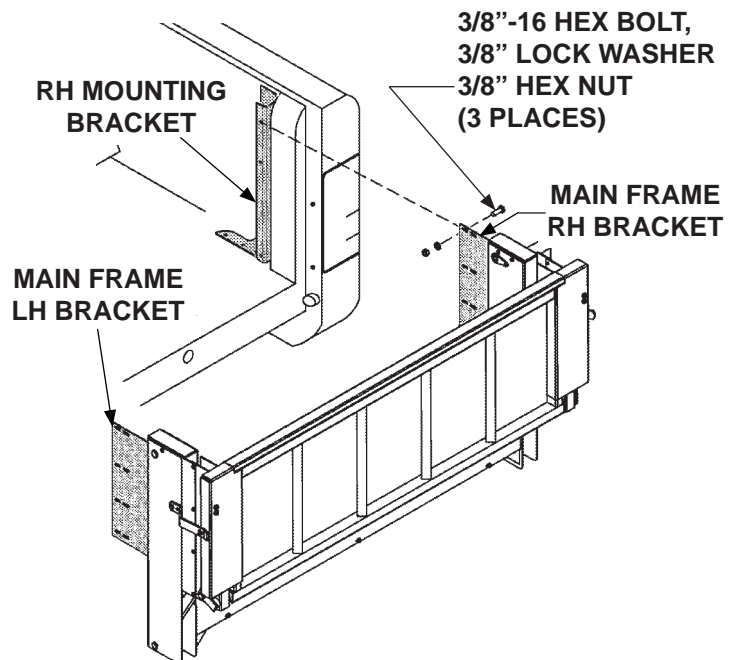

BOLTING LIFTGATE TO RH MOUNTING BRACKET
FIG. 10-2

INSTALLING LIFTGATE - Continued

- Let liftgate hang with support from corner posts of the pickup bed.

CAUTION

Before drilling holes in the pickup bed, ensure there are no obstructions to drill bit or items that could be damaged.

- Hold RH mounting bracket against corner post of the pickup bed (FIG. 11-1). Then, use 2 bracket holes to drill 2 holes for 3/8"-16 bolts in floor of the pickup bed (FIG. 11-1). Repeat for LH mounting bracket.

NOTE: For bolting steel brackets to aluminum truck body, only use the zinc-plated fasteners and aluminum spacers supplied with the bracket and bolt kits.

- Bolt RH mounting bracket to the floor of pickup bed as shown in FIG. 11-1. Repeat for LH mounting bracket.

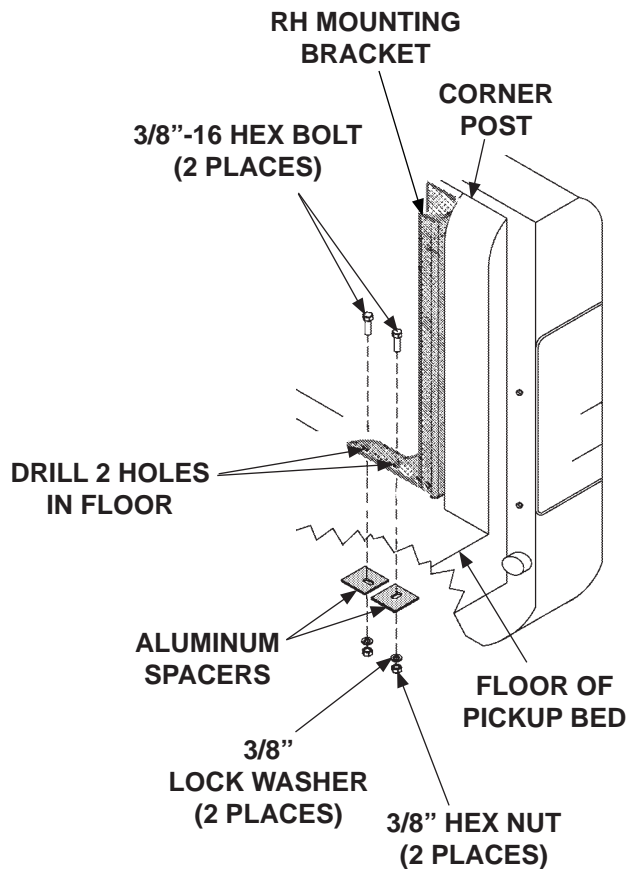

**BOLTING RH MOUNTING BRACKET TO PICKUP BED (LIFTGATE NOT SHOWN)
FIG. 11-1**

INSTALLING LIFTGATE - Continued

8. Use upper hole in the back of RH mounting bracket as a template to drill hole through inner side of corner post on pickup bed (FIG. 12-1). Then, bolt RH mounting bracket to corner post of pickup bed as shown in FIG. 12-1. Repeat for LH mounting bracket.

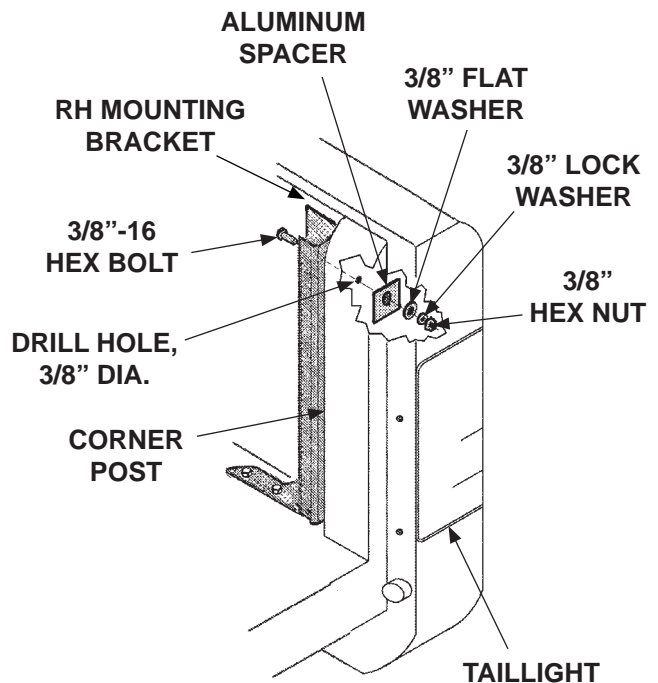

**BOLTING RH MOUNTING BRACKET TO PICKUP BED (LIFTGATE NOT SHOWN)
FIG. 12-1**

9. Unlatch and unfold platform. Refer to operation manual if needed. Then, adjust liftgate position so platform is level from front to back.

10. Securely tighten bolts fastening RH mounting bracket to main frame bracket (FIG. 12-1). Ensure the split lock washers are not in the slotted holes on main frame bracket. Repeat for LH mounting bracket.

11. Reinstall taillights (FIG. 12-1).

CHECKING ACCESS TO SPARE TIRE

CAUTION

Do not use a battery charger for connecting power to Liftgate power cables.

1. Connect power from a 12 volt truck battery to the Liftgate power cables extending from the back of main frame housing.
2. Refer to operating instructions, in **C2 Operation Manual**, to unfold platform and activate the Liftgate.

NOTE: With the **POWER ON** and **LIFTGATE ACTIVATED** lights on, the Liftgate can be raised or lowered. If the Liftgate is not used for 90 seconds, the control will automatically deactivate.

3. Use the control switch to lower (**DN**) the platform to the ground (**FIG. 13-1**).
4. Unbolt and remove cover from main frame housing (**FIG. 13-2**).

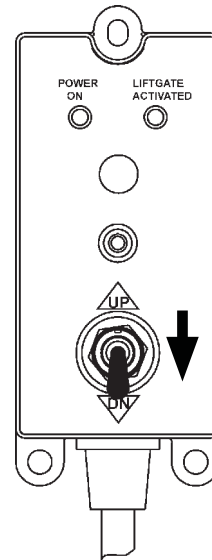

USING CONTROL SWITCH TO LOWER LIFTGATE
FIG. 13-1

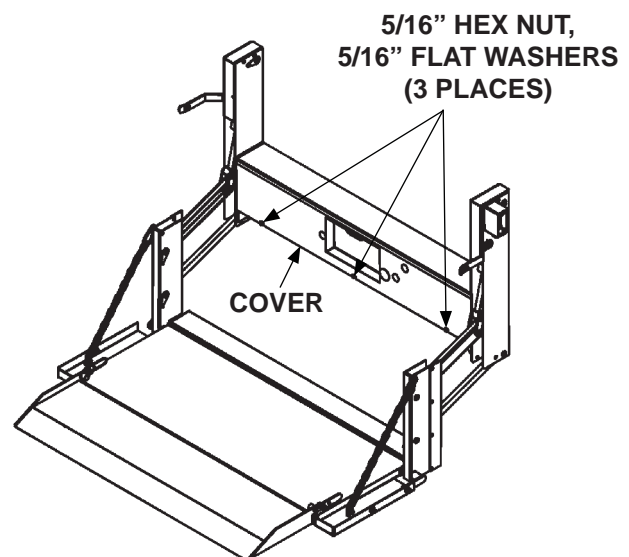

REMOVING HOUSING COVER FROM C2 LIFTGATE
FIG. 13-2

CHECKING ACCESS TO SPARE TIRE - Continued

5. Remove the correct black plastic plugs from the cover and mainframe (**FIG. 14-1**).

6. Insert the spare tire crank handle through the holes in the liftgate main frame.

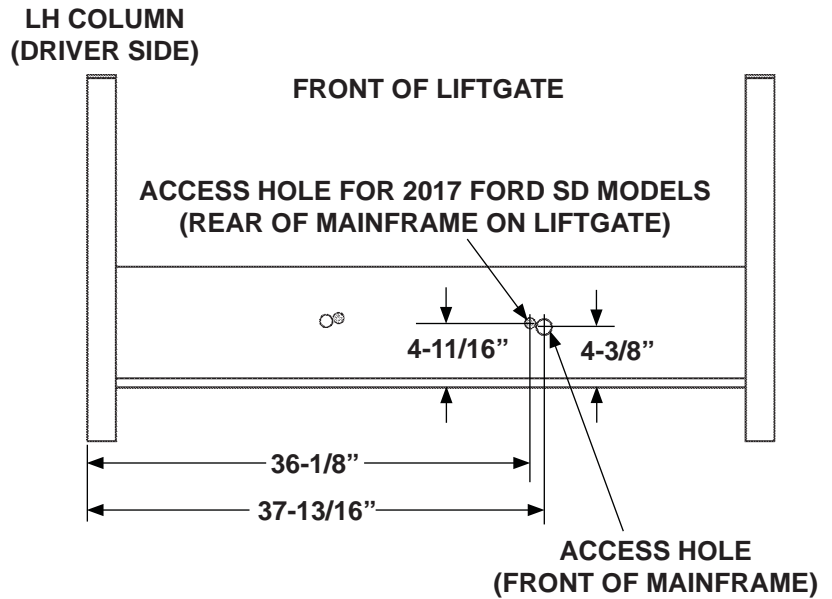

REMOVING PLASTIC PLUGS FOR SPARE TIRE ACCESS, FORD F-150 (2015)

FIG. 14-1

7. Ensure spare tire can be accessed using the crank handle.

ROUTING POWER CABLES

1. Remove the small parts and manual kit from the housing. Refer to **Sheet 4** for contents of the kits.
2. Install circuit breaker and bracket (Kit item) (**FIGS. 15-1 and 15-2**) on the truck battery tray inside the engine compartment (**FIG. 15-2**). Allow enough room for power cables to be run and for easy access to circuit breaker.

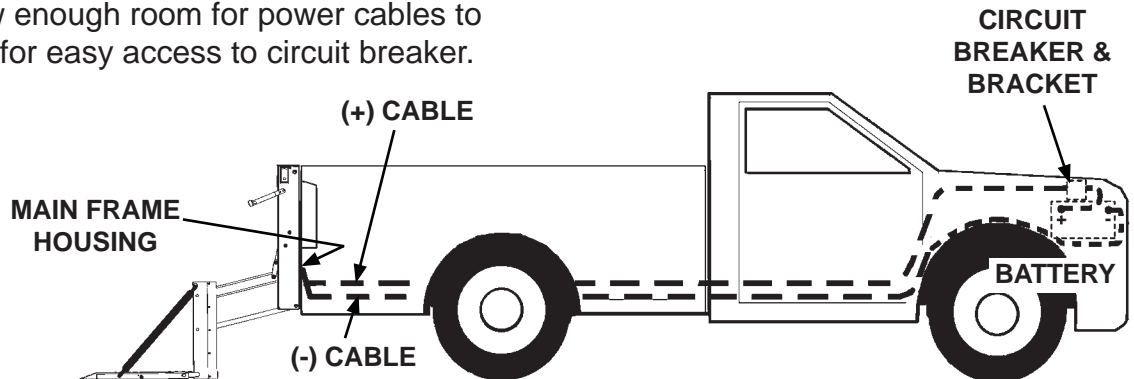

RUNNING POWER CABLES FROM LIFTGATE TO BATTERY
FIG. 15-1

3. Pull the **(+)** and **(-)** power cables through the cord grip on back of main frame housing. Leave about 2" of slack, for power cables, inside main frame housing.

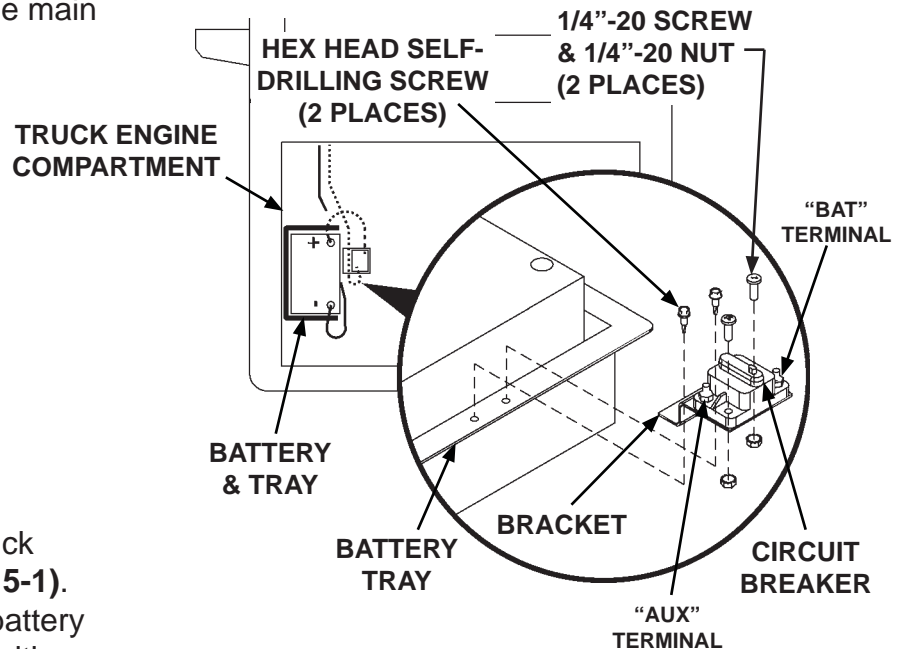

BOLTING CIRCUIT BREAKER & BRACKET TO TRUCK BATTERY TRAY (TOP VIEW)
FIG. 15-2

4. Route power cables along truck frame to truck battery (**FIG. 15-1**). Pull extra cable beyond the battery terminals. Then, separate positive **(+)** cable from negative **(-)** cable.

ROUTING POWER CABLES - Continued

5. Cut positive (+) cable to the length required to reach the **AUX** terminal of the circuit breaker (**FIGS. 16-2 and 16-3**), without putting strain on the connection. Install copper lug (Kit item) (**FIGS. 16-1 and 16-2**). Then, connect to **AUX** terminal on 150A circuit breaker (**FIGS. 16-2 and 16-3**).

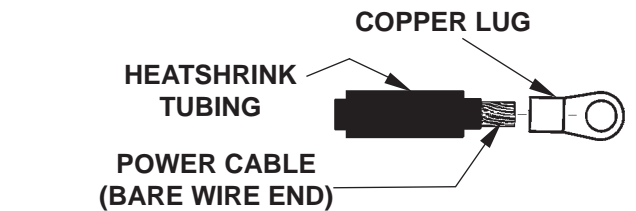

PLACING COPPER LUG & HEATSHRINK TUBING ON POWER CABLE

FIG. 16-1

6. Cut remaining positive (+) cable long enough to reach from the circuit breaker **BAT** terminal to the positive (+) battery terminal (**FIGS. 16-2 and 16-3**) without putting strain on the connection. Install copper lugs (Kit item) on both ends of cable (**FIGS. 16-1 and 16-2**). Then, connect cable to **BAT** terminal on 150A circuit breaker (**FIGS. 16-2 and 16-3**) and positive (+) terminal on battery (**FIG. 16-2**).



TYPICAL POWER CABLE WITH COPPER LUG INSTALLED

FIG. 16-2

7. Cut negative (-) cable to length required to reach negative (-) battery terminal (**FIG. 16-2**) without putting strain on the connection. Install copper lug (Kit item) (**FIGS. 16-1 and 16-2**). Then, connect cable to negative (-) terminal on battery (**FIG. 16-2**).

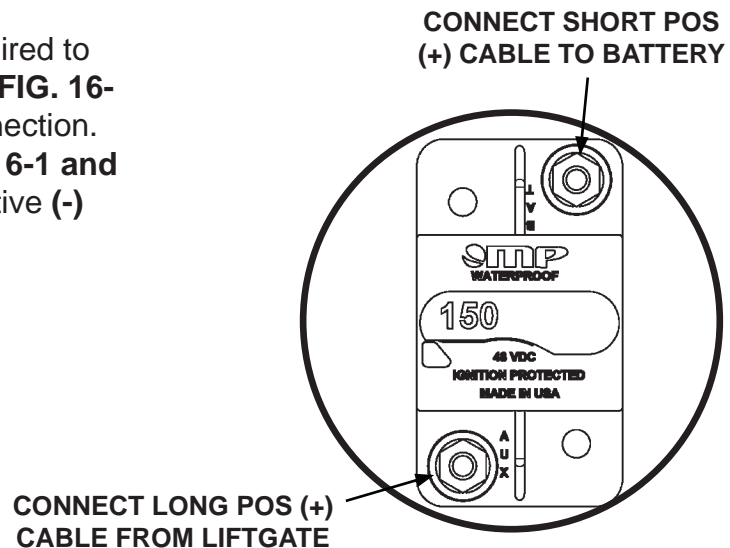

POWER CABLE CONNECTIONS TO 150A CIRCUIT BREAKER

FIG. 16-3

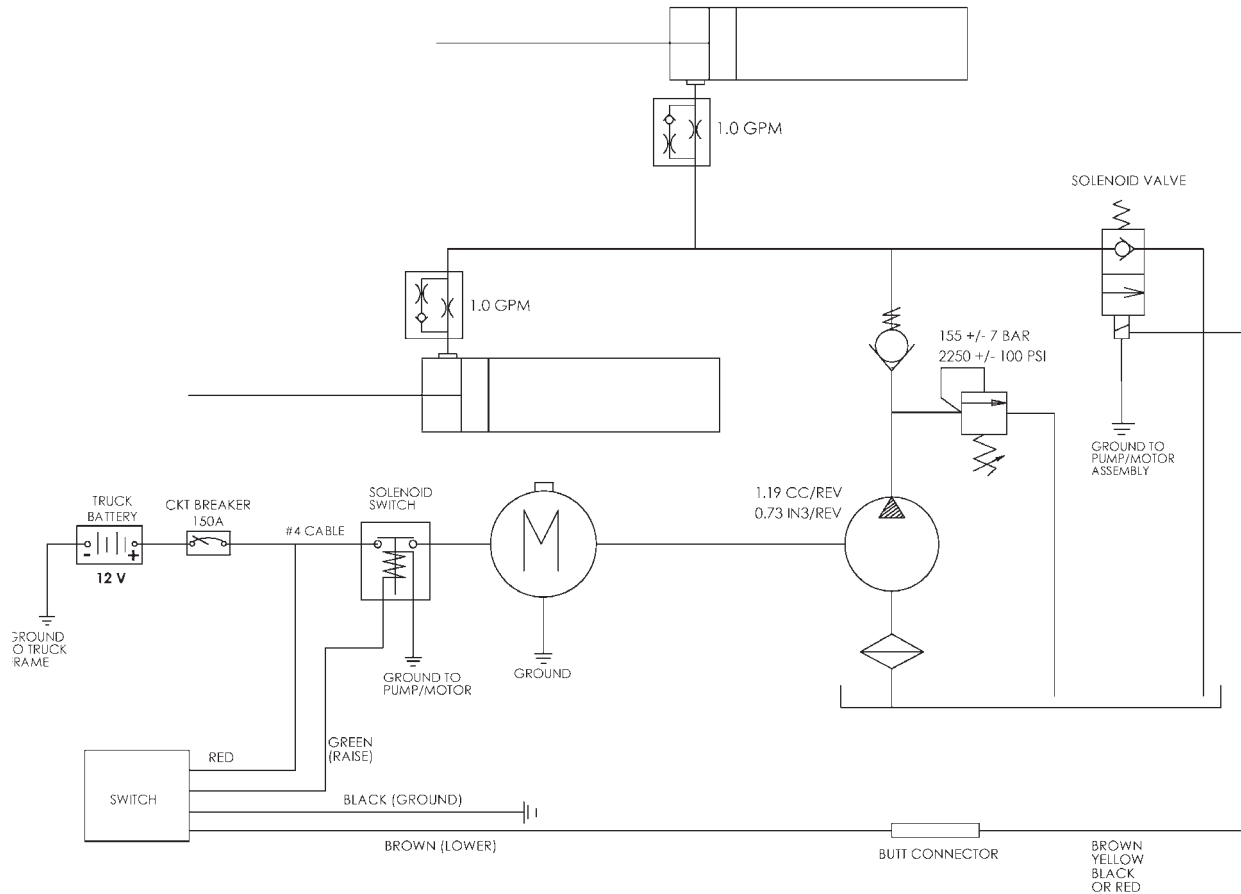

**C2 PICKUP LIFTGATE HYDRAULIC & ELECTRICAL SYSTEMS DIAGRAM
FIG. 17-1**

INSTALL LOWER MOUNTS

CAUTION

Liftgate can be severely damaged by connecting electric welder to liftgate at the wrong place. To prevent damage, always connect ground lead directly to component being welded & as close as possible to weld.

NOTE: Lower mounts are essential for Liftgate to be installed correctly. They attach to the truck frame and support the bottom of Liftgate.

1. Unbolt bracket plates from bottom of main frame housing (**FIG. 18-1**).
2. Position 2 bolt-on mounting angles, nearest to truck frame at bottom of Liftgate main frame housing (**FIG. 18-2**). Then bolt each angle to hole allowing closest fit to truck frame.
3. Position 2 bracket plates (Kit items) on truck frame at bottom of Liftgate main frame housing (**FIG. 18-2**). Bolt to truck frame. If necessary, modify bracket plates for best fit.
4. Clamp 2 short angles (no holes) (Kit items) to bracket plates on truck frame (**FIG. 18-2**). Position the 2 angles to reach the angles bolted on bottom of main frame housing.
5. With angles, and bracket plates positioned and clamped together, tack weld the angles and plates in position (**FIG. 18-2**).
6. Unbolt tack-welded lower brackets from truck frame (**FIG. 18-2**). Then, finish weld the bracket plates and angles.
7. Bolt the finish-welded bracket plates and angles back in position on the bottom of the main frame housing and truck frame (**FIG. 18-2**).

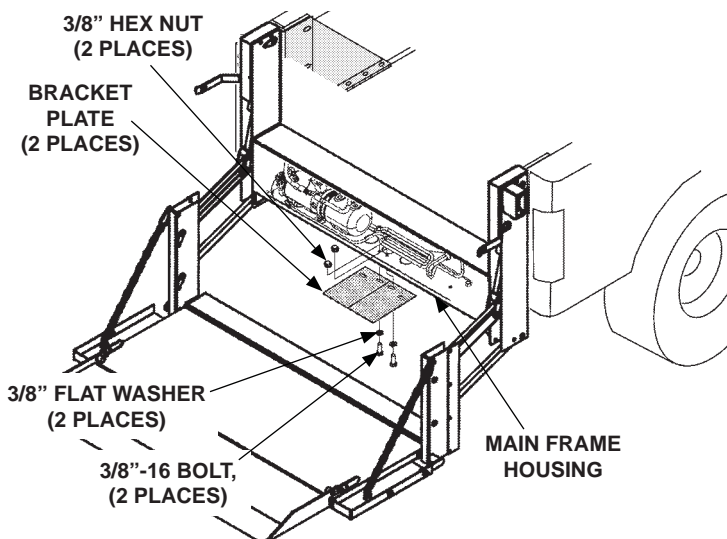

REMOVING BRACKET PLATES FROM MAIN FRAME HOUSING (C2 SHOWN)
FIG. 18-1

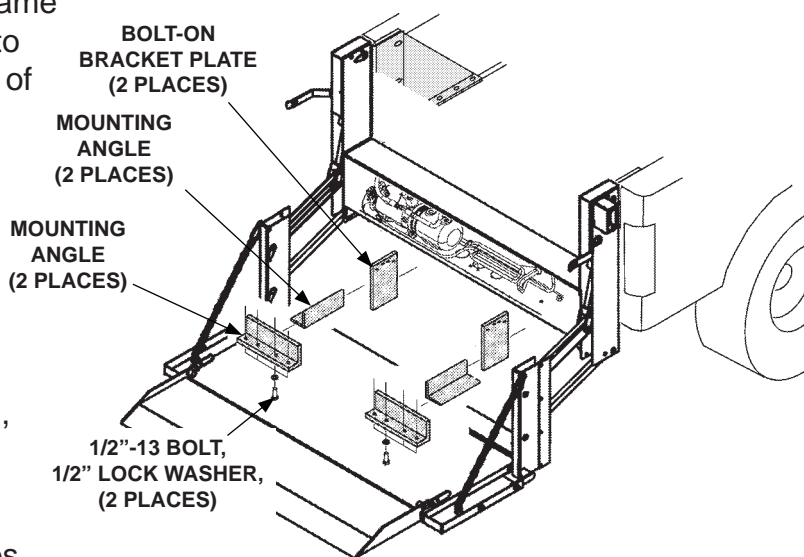

FABRICATING LOWER BRACKETS TO SUPPORT LIFTGATE (C2 SHOWN)
FIG. 18-2

COMPLETE LIFTGATE INSTALLATION

CAUTION

Hydraulic system is filled at the factory with correct amount of oil. It is unnecessary to add more oil except as required for periodic maintenance of the liftgate.

1. Remove the solid plug from the pump reservoir (FIG. 19-1). Install breather plug (Kit item) in pump reservoir.

2. Bolt on main frame cover (FIG. 19-2).

3. Install the two square plastic grommet nuts (Kit item), for the license plate, into the square holes on the Liftgate main frame cover (FIG. 19-2).

4. Install the license plate using two 1/4"-20 self-tapping screws (Kit item) (FIG. 19-2).

5. Install the license plate lights into the holes provided. Refer to instruction sheet M-14-35. Then, connect the license plate lights to the vehicle's wiring.

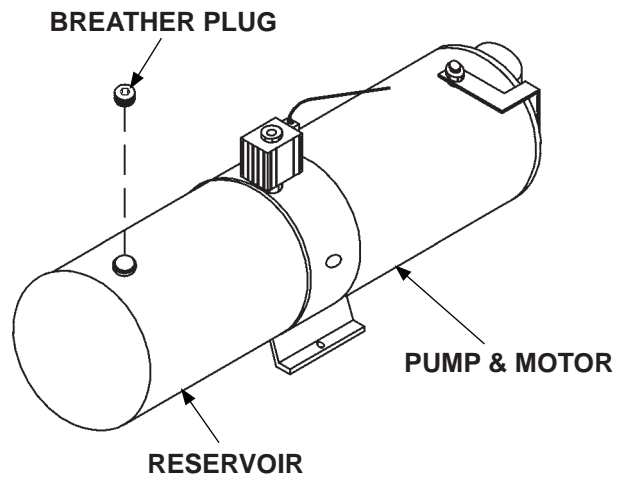

INSTALLING VENT PLUG ON
PUMP RESERVOIR
FIG. 19-1

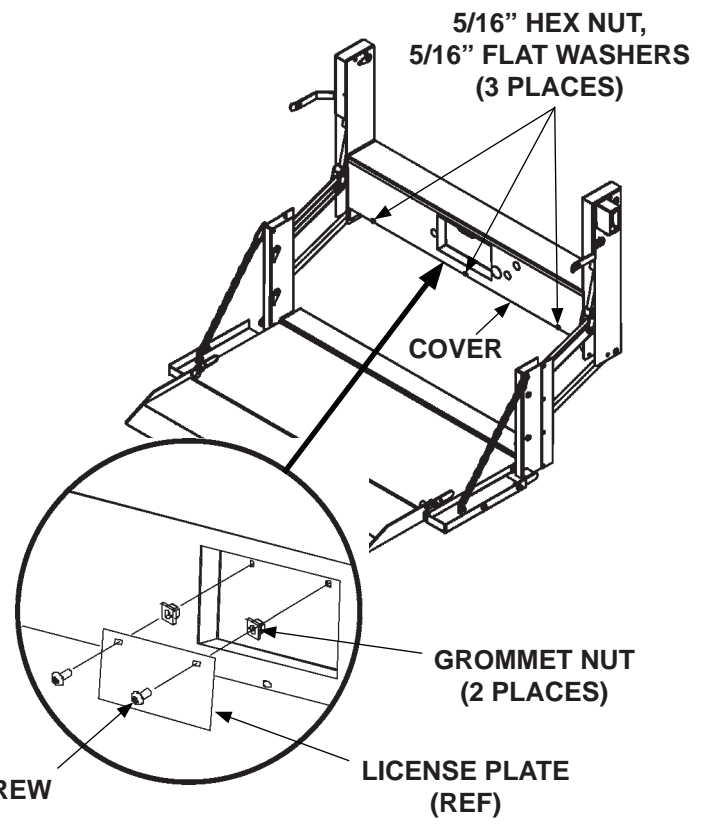

INSTALLING COVER & LICENSE PLATE
(C2 LIFTGATE SHOWN)
FIG. 19-2

COMPLETE LIFTGATE INSTALLATION - Continued

6. To use the drop-away platform feature, install drop pin and 3/8"-16 lock nut (Kit items) on the bottom of RH column (FIG. 20-1). Tighten lock nut securely.

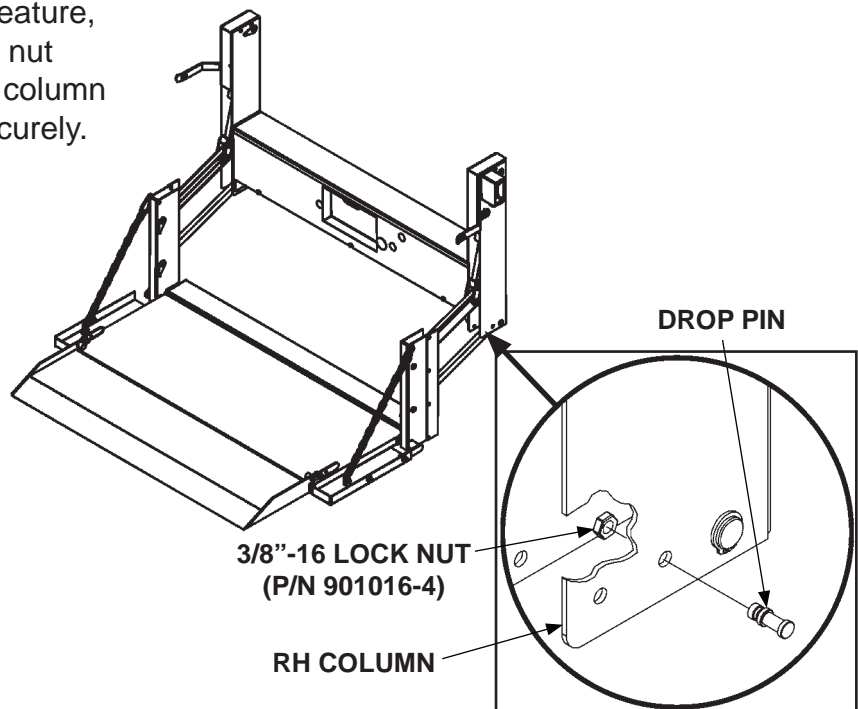

**INSTALLING DROP PIN ON
RH COLUMN (C2 LIFTGATE SHOWN)
FIG. 20-1**

7. Install the 3/8" round plastic plugs into the empty holes in the bottom of the columns.
8. If previously removed, reinstall spare tire.

TEST OPERATION OF LIFTGATE

! WARNING

Keep all foreign objects out of the Liftgate mainframe and away from pinch points at all times when operating Liftgate.

NOTE: The **LIFTGATE ACTIVATED** LED illuminates when Liftgate power is on. Control switch should deactivate after 90 seconds of not being used.

1. Check operation of control switch for proper operation by pressing **POWER ON** button once to activate. Next, press **POWER ON** button again to deactivate Liftgate power. Then, press the **POWER ON** button twice to reset low voltage (**FIG. 21-1**).
2. Press the **LIFTGATE ACTIVATED** switch within 1 second to activate the timer (**FIG. 21-1**).
3. Raise (**UP**) and lower (**DN**) the unloaded platform (**FIGS. 21-1** and **21-2**) on a flat surface. Check for proper operating speed and alignment with the ground.
4. Load the platform with the rated capacity and measure the time to **RAISE** the platform (**FIG. 21-1**). The platform should raise approximately 2" to 3" per second.
5. Examine platform for drift-down. If you experience platform drift-down, remove vent plug from pump reservoir. Check and clean any debris from vent plug. Then, reinstall vent plug.
6. Measure the time to **LOWER** the platform still loaded (**FIG. 21-2**). The load should descend approximately 7" to 9" per second.
7. Remove the load from the platform and examine the Liftgate and vehicle for hydraulic oil leaks, loose wiring, and any other problems.
8. Reinstall the main frame housing cover. Then, close and latch platform.

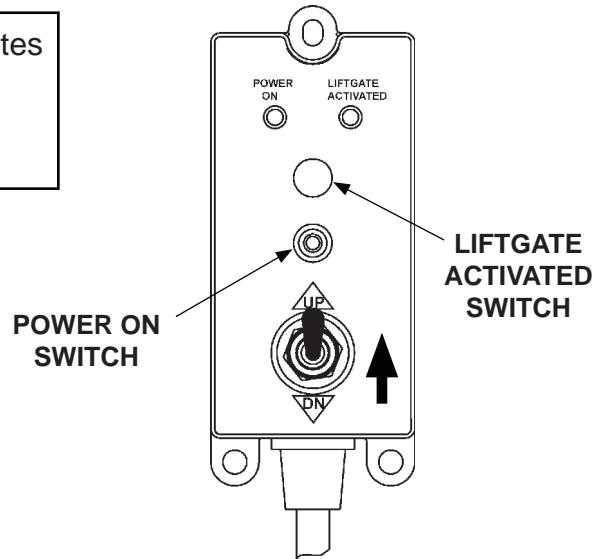

**CHECKING OPERATION OF CONTROL SWITCH AND RAISING PLATFORM
FIG. 21-1**

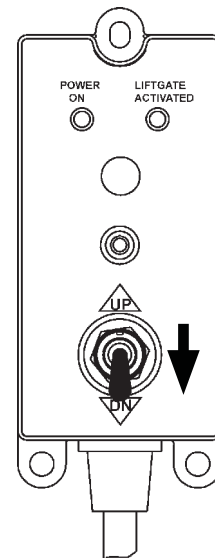

**USING CONTROL SWITCH TO LOWER PLATFORM
FIG. 21-2**

TEST OPERATION OF LIFTGATE - Continued

9. Lock the latch on LH side or RH side through the hole in the latch pin (**FIG. 22-1**).

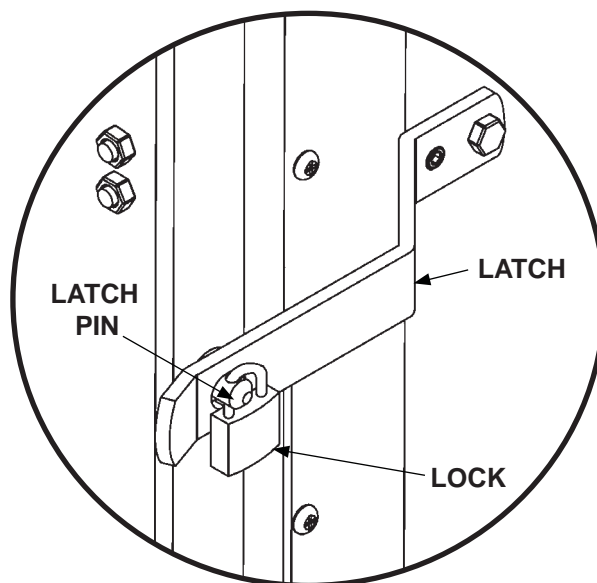

**LOCKING PLATFORM
(C2 LIFTGATE)
FIG. 22-1**